

## DESMI Triple Screw Pump

### OPERATION AND MAINTENANCE INSTRUCTIONS

#### TSP K – Radial shaft seal version

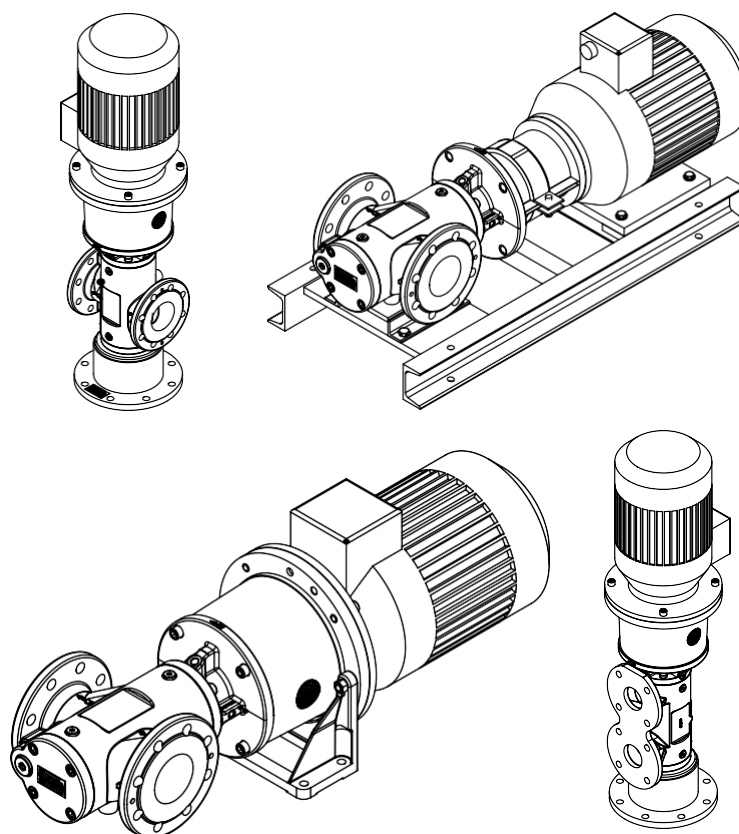

**DESMI Pumping Technology A/S**  
Tagholm I, DK-9400 Nørresundby, Denmark

**Tel.: +45 96 32 81 11**

**Fax: +45 98 17 54 99**

**E-mail: [desmi@desmi.com](mailto:desmi@desmi.com)**

**Internet: [www.desmi.com](http://www.desmi.com)**

Manual: T1800	Language: English	Revision: A.1(07/24)
------------------	----------------------	-------------------------

Special pump Number. ....

<b>1 About this document</b> .....	<b>4</b>	<b>Operation</b> .....	<b>20</b>
1.1 General information .....	4	10.1 Dangers during operation .....	20
1.2 Associated documents .....	4	10.2 Commissioning .....	20
1.3 Target groups .....	4	10.2.1 Cleaning the pipe system .....	20
1.4 Symbols .....	4	10.2.2 Filling and venting the pump .....	20
1.4.1 Danger levels .....	4	10.2.3 Checking the direction of rotation .....	22
1.4.2 Danger signs .....	5	10.2.4 Commissioning the pump .....	22
1.4.3 Symbols in this document .....	5	10.3 During operation .....	24
<b>2 Safety</b> .....	<b>5</b>	10.3.1 Checking the operating pressure .....	24
2.1 Proper use .....	5	10.3.2 Monitoring the filter and/or strainer .....	24
2.2 Foreseeable misuse .....	5	10.3.3 Adjusting the overflow valve .....	24
2.3 Obligations of the operator-owner .....	6	10.3.4 Test the overflow valve .....	25
2.4 Safety instructions .....	6	10.3.5 Switching off the pump unit .....	26
2.4.1 Fundamental safety instructions .....	6	10.4 Decommissioning .....	26
<b>3 Identification</b> .....	<b>6</b>	10.4.1 Decommissioning the pump .....	26
3.1 Type code .....	6	10.5 Recommissioning .....	27
3.2 Rating plate .....	7	10.5.1 Recommissioning the pump .....	27
<b>4 Technical data</b> .....	<b>8</b>	<b>11 Maintenance</b> .....	<b>27</b>
4.1 Operating limits .....	8	11.1 Dangers during maintenance .....	27
4.2 Required NPSH values .....	8	11.2 Required maintenance .....	27
4.3 Sound pressure level .....	8	11.3 Ball bearing .....	27
4.4 Weights .....	9	11.4 Maintaining the pump .....	28
4.5 Accessories .....	9	11.5 Cleaning the leakage vent hole .....	28
<b>5 Function description</b> .....	<b>9</b>	<b>12 Servicing</b> .....	<b>28</b>
5.1 Pump structure .....	9	12.1 Instruction videos .....	28
5.2 Pump unit structure .....	10	12.2 Dangers during servicing .....	29
5.3 Functional principle .....	10	12.3 Wear .....	29
5.4 Housing variants .....	10	12.3.1 Signs of wear .....	29
5.5 Shaft seal .....	11	12.3.2 Radial shaft seal .....	29
5.6 Overflow valve .....	11	12.4 Replacing the overflow valve .....	29
<b>6 Transportation, storage</b> .....	<b>12</b>	12.4.1 Removing the overflow valve .....	29
6.1 Dangers during transportation .....	12	12.4.2 Installing the overflow valve .....	30
6.2 Dangers during storage .....	12	12.5 Replacing the coupling .....	30
6.3 Unpacking and checking the state of delivery .....	12	12.5.1 Removing the coupling .....	30
6.4 Transporting the pump/pump unit .....	12	12.5.2 Installing the coupling .....	31
6.5 Storing the pump .....	13	12.6 Replacing the ball bearing and radial shaft seal .....	32
<b>7 Preservation</b> .....	<b>14</b>	12.6.1 Removing the ball bearing and radial shaft seal .....	32
7.1 Preservation table .....	14	12.6.2 Mounting the ball bearing and radial shaft seal .....	33
7.2 Preserving the inner surfaces .....	14	12.7 Replacing the screw set .....	34
7.3 Preserving the outer surfaces .....	14	12.7.1 Removing the screw set .....	34
7.4 Removing the preservation .....	14	12.7.2 Installing the screw set .....	35
<b>8 Installation, removal</b> .....	<b>15</b>	<b>13 Disposal</b> .....	<b>35</b>
8.1 Dangers during installation .....	15	13.1 Dismantling and disposing of the pump .....	35
8.2 Dangers during removing .....	15	<b>14 Troubleshooting</b> .....	<b>36</b>
8.3 Installing the pump .....	15	14.1 Possible faults .....	36
8.4 Removing the pump .....	16	14.2 Troubleshooting .....	36
<b>9 Connection</b> .....	<b>17</b>	<b>15 Accessories</b> .....	<b>38</b>
9.1 Dangers during connection work .....	17	15.1 Heating .....	38
9.2 Connecting the pump to the pipe system .....	17	15.1.1 Possible types of heating .....	38
9.3 Insulating the pump .....	18	15.1.2 Electrical heating system .....	38
9.4 Assembling the pump and motor .....	18	15.1.3 Fluid heating system .....	40
9.5 Connecting the pump unit to the power supply .....	19	15.1.4 Heating system special design .....	41
		<b>16 Spare parts</b> .....	<b>42</b>
		16.1 Overview .....	42

16.2	Maintenance kits.....	43
16.2.1	Maintenance kit radial shaft seal standard or high-temperature KF/KH/KV 5 – 660 .....	43
16.2.2	Maintenance kit radial shaft seal standard or high-temperature KF/KH/KV 851 – 1301 .....	44
16.2.3	Maintenance kit radial shaft seal standard or high-temperature KF/KH/KV 1500 – 1700 .....	45
16.2.4	Maintenance kit radial shaft seal standard or high-temperature KF/KH/KV 2200 – 2900 .....	46
16.2.5	Maintenance kit radial shaft seal standard or high-temperature KFT/KVT/KFN .....	47
16.3	Repair kits.....	48
16.3.1	Repair kit overflow valve KF/KH/KV 5 – 660 and KFT/KVT/KFN/KFA .....	48
16.3.2	Repair kit overflow valve KF/KH/KV 851 – 1301 .....	49
16.3.3	Repair kit overflow valve KF/KH/KV 1500 – 1700 .....	50
16.3.4	Repair kit overflow valve KF/KH/KV 2200 – 2900 .....	51
16.3.5	Spindle set repair kit K .....	52
16.4	Tool sets.....	52
16.4.1	Radial shaft seal tool set K.....	52
16.5	Completions.....	53
16.5.1	Completion Type KF.....	53
16.5.2	Completion Type KH .....	54
16.5.3	Completion Type KV .....	55
<b>17</b>	<b>Appendix.....</b>	<b>56</b>
17.1	Tightening torques for screws with metric screw threads with and without wedge lock washers .....	56
17.2	Tightening torques for screw plugs with thread measured in inches and elastomer seal.....	56
17.3	Contents of the Declaration of Conformity .....	57

## 1.1 General information

### 1 About this document

#### 1.1 General information

These instructions form part of the product and must be kept for future reference. Furthermore please observe the associated documents.

#### 1.2 Associated documents

- Declaration of conformity according to EU Directive 2006/42/EC
- Manufacturer's declaration according to EU Directive 2014/68/EU
- Data sheet of the pump
- Technical documentation of the supplied components

#### 1.3 Target groups

The instructions are intended for the following persons:

- Persons who work with the product
- Operator-owners who are responsible for the use of the product

Persons who work with the product must be qualified. The qualification ensures that possible dangers and material damage that are connected to the activity are detected and avoided. These persons are qualified personnel who carry out the work properly due to their training, knowledge and experience and on the basis of the relevant provisions.



Information on the required qualification of the personnel is provided separately at the beginning of the individual chapters in these instructions. The following table provides an overview.

Target group	Activity	Qualification
Transport personnel	Transporting, unloading, setting up	Qualified personnel for transport, mobile crane operators, crane operators, forklift operators
Fitter	Mounting, connection	Qualified personnel for mounting
Electrician	Electrical connection	Qualified personnel for electric installation
Trained personnel	Delegated task	Personnel trained by the operator-owner who know the task delegated to them and the possible dangers arising through improper behaviour.







Tab. 1: Target groups

#### 1.4 Symbols







##### 1.4.1 Danger levels

	Signal word	Danger level	Consequences of non-observance
	DANGER	Immediate threat of danger	Serious personal injury, death
	WARNING	Possible threat of danger	Serious personal injury, invalidity
	CAUTION	Potentially dangerous situation	Slight personal injury
	ATTENTION	Potentially dangerous situation	Material damage

## 1.4.2 Danger signs

	Meaning	Source and possible consequences of non-observance
	Electrical voltage	Electrical voltage causes serious physical injury or death.
	Raised load	Falling objects can result in serious physical injury or death.
	Heavy load	Heavy loads can result in serious back problems.
	Risk of slipping	Discharging pumped liquid and oils on the foundation or tread surfaces can cause falls with serious physical injury or death.
	Flammable substances	Discharging pumped liquid and oils can be easily inflammable and can result in serious burns.
	Hot surface	Hot surfaces can cause burns.

## 1.4.3 Symbols in this document

	Meaning
	Warning personal injury
	Safety instruction
	Request for action
	Multi-step instructions for actions
	Action result
	Cross-reference

## 2 Safety

### 2.1 Proper use

- Use the pump solely for transporting lubricating liquids that are chemically neutral and that do not contain gas or solid components.
- Use the pump only within the operating limits specified on the rating plate and in the chapter "Technical data". In the case of operating data that do not agree with the specifications on the rating plate, please contact the manufacturer.
- The pump is designed specially for the operating pressure named by the customer. If the actual operating pressure deviates notably from this design pressure, damage to the pump can also arise within the specified operating limits. This applies both to notably higher as well as to notably lower operating pressures. Under no circumstances may the minimum pressure lie below 2 bar. In case of any doubt, please contact the manufacturer.

### 2.2 Foreseeable misuse

- Any use that extends beyond the proper use or any other use is misuse.
- The product is not suitable for pumping liquids outside the operational limits.
- Any bypassing or deactivation of safety equipment during operation is prohibited.

## 2.3 Obligations of the operator-owner

### 2.3 Obligations of the operator-owner

The operator-owner is the person who operates the product commercially or permits a third party to use it and who bears the legal responsibility for the product, the protection of the personnel and third parties during its operation.

The product is used in industrial applications. The operator-owner is therefore subject to the statutory obligations concerning occupational health and safety.

In addition to the safety instructions in these instructions, the regulations on safety, accident prevention and environmental protection respectively valid for the range of application of the product are to be observed.

### 2.4 Safety instructions

#### 2.4.1 Fundamental safety instructions



**The following safety instructions must be observed strictly:**

- Read these operating instructions carefully and observe them.
- Read the operating instructions of the components carefully and observe them.
- Have work only carried out by qualified personnel/trained personnel.
- Wear personal protective equipment and work carefully.
- Pumped liquids can be subject to high pressure and can result in personal injury and damage to property in case of incorrect operation or damaged components.
- Pumped liquids can be hot, poisonous, combustible and caustic. Use corresponding protective equipment.
- Observe the associated data sheets and safety regulations when handling dangerous materials.
- Avoid skin contact with system parts carrying liquids at operating temperatures exceeding 60 °C.
- Collect any discharging pumped liquid safely and dispose of it in an environmentally compatible manner in accordance with the applicable local regulations. Neutralize residues.
- Keep the mounting surfaces, scaffolding, ladders, lifting platforms and tools clean in order to prevent slipping or stumbling.
- If pressurized or energized components are damaged, shut down the pump immediately. Replace the components or pump.

## 3 Identification

### 3.1 Type code

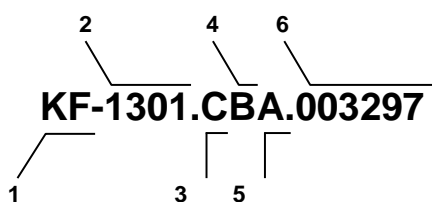

Fig. 1: Type code

Item	Classification	Description
1	Type	KF <ul style="list-style-type: none"> <li><input type="checkbox"/> Pump with free shaft end</li> <li><input type="checkbox"/> Pump with inline flanges</li> <li><input type="checkbox"/> Pump unit with or without pump bracket foot</li> </ul>
		KFA <ul style="list-style-type: none"> <li><input type="checkbox"/> Pump with free shaft end</li> <li><input type="checkbox"/> Pump with overhead flanges in special design</li> <li><input type="checkbox"/> Pump unit with or without pump bracket foot</li> </ul>
		KFN <ul style="list-style-type: none"> <li><input type="checkbox"/> Pump with free shaft end</li> <li><input type="checkbox"/> Pump with overhead flanges</li> <li><input type="checkbox"/> Pump unit with or without pump bracket foot</li> </ul>
		KFT <ul style="list-style-type: none"> <li><input type="checkbox"/> Pump with free shaft end</li> <li><input type="checkbox"/> Pump with overhead flanges</li> <li><input type="checkbox"/> Pump unit with or without pump bracket foot</li> </ul>

Item	Classification	Description
		KH <ul style="list-style-type: none"> <li><input type="checkbox"/> Pump with foot for horizontal mounting</li> <li><input type="checkbox"/> Pump with inline flanges</li> <li><input type="checkbox"/> Pump unit on base frame</li> </ul>
		KV <ul style="list-style-type: none"> <li><input type="checkbox"/> Pump with pedestal for vertical mounting</li> <li><input type="checkbox"/> Pump with inline flanges for vertical mounting</li> <li><input type="checkbox"/> Pump unit on pedestal for vertical mounting</li> </ul>
		KVT <ul style="list-style-type: none"> <li><input type="checkbox"/> Pump with pedestal for vertical mounting</li> <li><input type="checkbox"/> Pump with overhead flanges PN16 for vertical mounting</li> <li><input type="checkbox"/> Pump unit on pedestal for vertical mounting</li> </ul>
2	Size	Corresponds to delivery rate in [l/min] at 1450 min <sup>-1</sup>
3	Shaft seal	A Standard mechanical seal
		B Mechanical seal of hard material
		C Standard radial shaft seal
		D Magnetic coupling
		E Mechanical seal with quench
		F High-temperature radial shaft seal
		X Special design
4	Pressure stage overflow valve	A Pressure stage 3.0 – 5.9 bar
		B Pressure stage 6.0 – 9.9 bar
		C Pressure stage 10 – 16 bar
		X Special design
5	Heating	A Without heating
		B Electrical heating system
		C Fluid heating system
		X Special design
6	Version index	For internal administration

Tab. 2: Type code

### 3.2 Rating plate

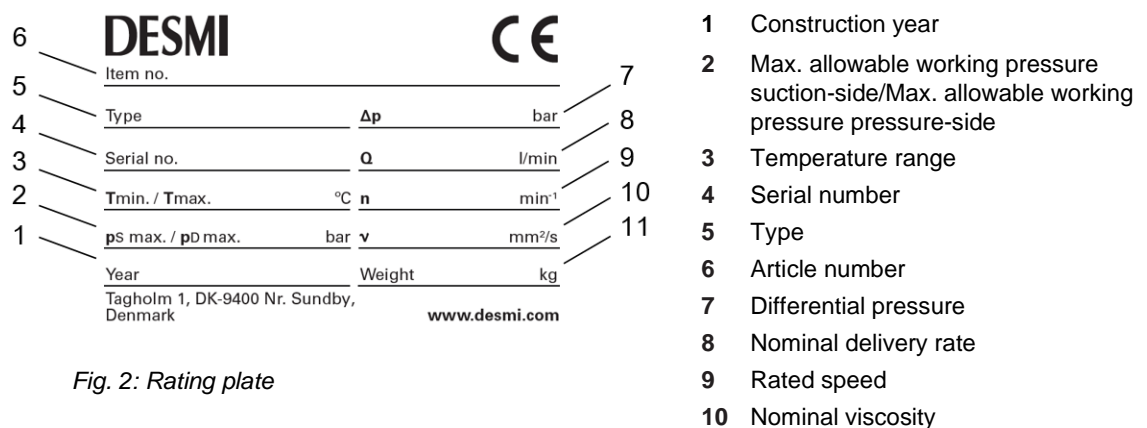

Fig. 2: Rating plate

## 4.1 Operating limits

### 4 Technical data

#### 4.1 Operating limits

Parameter	Unit	Size									
		5 – 20	32 – 42	55 – 118	160 – 275	370 – 450	550 – 660	851 – 1301	1500 – 1700	2200 – 2900	
<b>Max. operating overpressure</b>											
<input type="checkbox"/> Pump with flange PN6	[bar]	6									
<input type="checkbox"/> Pump with flange PN16	[bar]	16									
<b>Max. temperature of the pumped liquid</b>											
<input type="checkbox"/> Standard radial shaft seal	[°C]	80									
<input type="checkbox"/> High-temperature radial shaft seal	[°C]	150									
<input type="checkbox"/> Shaft seal special design	[°C]	Customer-specific, contact the manufacturer									
<b>Min. temperature of pump materials</b>	[°C]	-10									
<b>Min. – max. ambient temperature</b>	[°C]	-20 ... 50									
<b>Viscosity min. – max.</b>	[mm <sup>2</sup> /s]	1.5 – 10000									
<b>Max. speed</b>											
<input type="checkbox"/> At 50 Hz	[min <sup>-1</sup> ]	2900					1450				
<input type="checkbox"/> At 60 Hz	[min <sup>-1</sup> ]	3500					1750				
<b>Max. inlet pressure</b>											
<input type="checkbox"/> Radial shaft seal	[bar]	6									
<input type="checkbox"/> Shaft seal special design	[bar]	Customer-specific, contact the manufacturer									

Tab. 3: Operating limits

#### 4.2 Required NPSH values

The required NPSH values of the pump depend on the size, the viscosity of the pumped liquid and the speed.

#### 4.3 Sound pressure level

Guide values at 1 m distance, 1450 min<sup>-1</sup>, 10 bar

	Size									
	5 – 20	32 – 42	55 – 118	160 – 275	370 – 450	550 – 660	851 – 1301	1500 – 1700	2200 – 2900	
<b>Max. sound pressure level ±3 [dB(A)]</b>										
Pump	53.0	57.0	59.0	63.0	65.0	69.0	71.0	74.0	80.5	
Motor	52.0	59.0	63.0	65.0	67.0	67.0	73.0	73.0	75.0	
Pump unit	55.5	61.0	64.5	67.0	69.0	71.0	75.0	76.5	82.0	

Tab. 4: Sound pressure level



### 4.4 Weights

The weight is specified on the rating plate.

### 4.5 Accessories

**Note** The technical data of the accessories are specified separately ↪ Accessories, Page 38.

## 5 Function description

### 5.1 Pump structure

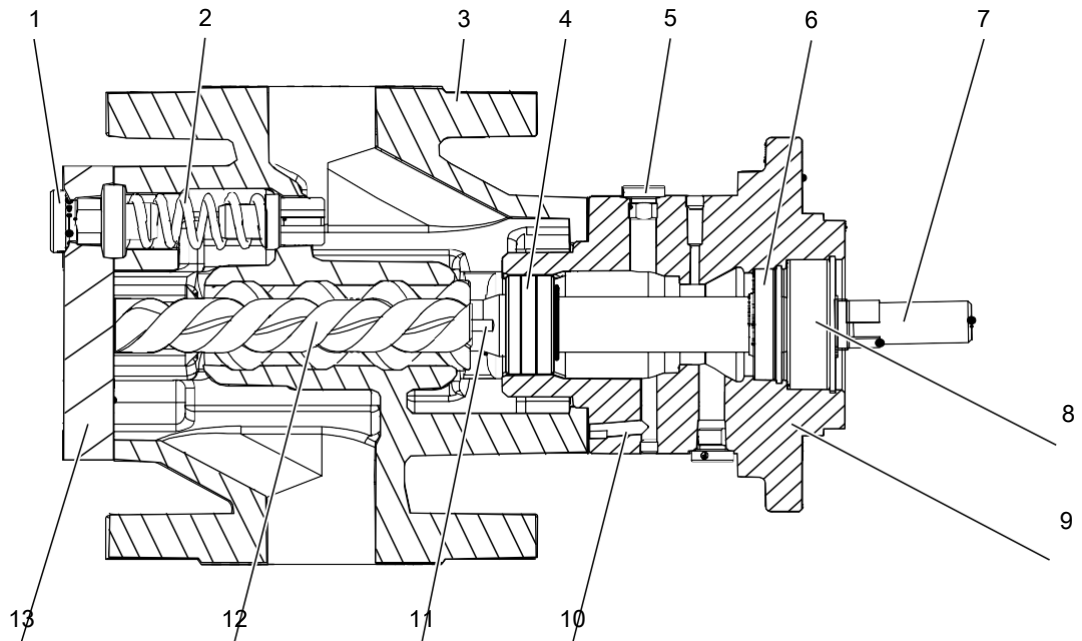

Fig. 3: Pump structure

1	Screw plug	8	Ball bearing
2	Overflow valve	9	Pump flange
3	Pump housing	10	Relief line
4	Balancing cylinder	11	Thrust pin
5	Venting sealing chamber	12	Idle screw
6	Shaft seal (radial shaft seal)	13	End cover
7	Main screw		

## 5 Function description

### 5.2 Pump unit structure

#### 5.2 Pump unit structure

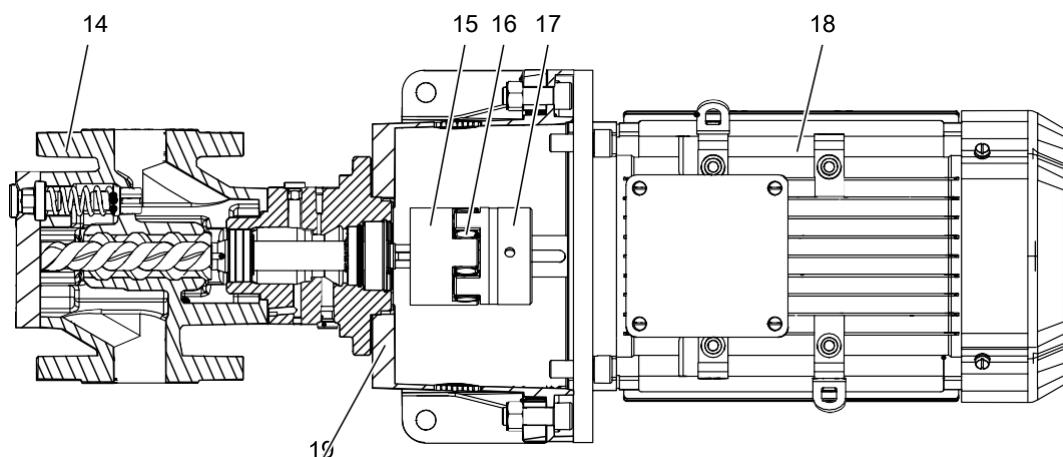

Fig. 4: Pump unit structure

<b>14</b>	Pump	<b>17</b>	Motor-side coupling half
<b>15</b>	Pump-side coupling half	<b>18</b>	Motor
<b>16</b>	Coupling intermediate ring	<b>19</b>	Pump bracket

#### 5.3 Functional principle

Screw pumps are rotating displacement pumps. The displacement effect results from three rotating screws **7** and **12** and the enclosing pump housing **3**.

Radial support of the screw set is provided through the sliding contact in the pump housing that depends on lubrication by the pumped liquid. Screw pumps are therefore not suitable for dry running and can only be used up to specific pressure limits and viscosity limits. Due to the narrow gap dimensions, suspended solids cannot be pumped.

The axial support of the main screw is provided by a lifetime-lubricated ball bearing **8**. Various shaft seals **6** are available for sealing the main screw at the outlet from the housing. In order to reduce the pressure at the shaft seal, a balancing cylinder **4** is mounted at the main screw. The sealing chamber is connected to the suction chamber via a relief line **10**. An integrated overflow valve **2** protects against excessive pressure that could cause housing parts to burst.

The default direction of the rotation of the screw set is clockwise viewed from the motor **18** and is marked on the pump flange **9** by an arrow.

The flow direction is marked on the pump housing **3** by two arrows.

#### 5.4 Housing variants

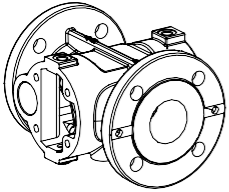
Housing	Type	Description
	KF/KH/KV	Flange arrangement: Inline flange PN16

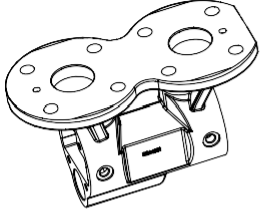
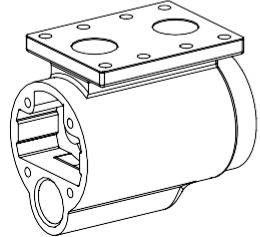
Housing	Type	Description
	KFN/KFT/KVT	Flange arrangement: Overhead flange PN6/PN16
	KFA	Flange arrangement: Overhead flange in special design PN16

Tab. 5: Housing variants

### 5.5 Shaft seal

The following types of shaft seals are used:

- Radial shaft seal, standard or high-temperature

#### Radial shaft seal

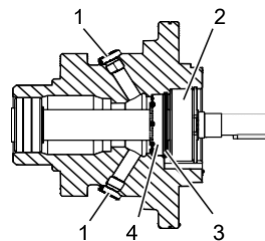

- 1 Screw plug
- 2 Ball bearing
- 3 Circlip
- 4 Radial circlip

Depending on the material used, radial shaft seals can be used for temperatures of up to 80 °C or 150 °C respectively. The used shaft seal rings each have a lip used to seal against liquid outlet and air inlet.

Tab. 6: Seal variants

### 5.6 Overflow valve

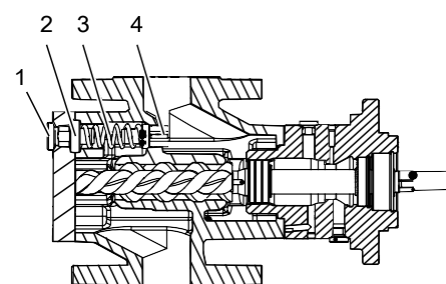

- 1 Screw plug
- 2 Adjusting screw
- 3 Pressure spring
- 4 Valve body

Fig. 5: Overflow valve

The integrated overflow valve ensures that very high pressures that could result in housing parts bursting do not arise.

The overflow valve is purely there as a safety element for the pump and should not be used for control or regulation purposes such as maintaining pressure. If the valve is kept open for too long under adverse operating conditions (high differential pressures and/or low viscosities) it will only take a few minutes for the overflow valve and the valve seating to become damaged. As a result, the overflow valve will leak permanently and there will be a corresponding reduction in the delivery rate. In addition to this, circulation through the overflow valve for too long results in excess heating of the pump. This reduces viscosity and can ultimately lead to pump failure.

It therefore has to be ensured at the system by a safety valve that the maximum allowable working pressure always lies under the opening pressure of the overflow valve.

## 6 Transportation, storage

### 6.1 Dangers during transportation

**Note** The opening pressure of the overflow valve is set to 110% of the differential pressure in the factory. The overflow valve is accessible through a screw plug **1** and can be adjusted from the outside ↪ During operation, Page 24.

- Note**  A function test of the overflow valve at least every 5 years is essential for the safe operation ↪ During operation, Page 24.
- Scope and if necessary shorter test intervals must be specified by the operator-owner in accordance with the requirements and national provisions (for example Austrian Ordinance of Safety and Health (BetrSichV)).
  - The first function test must take place directly after the commissioning.
  - After longer downtimes (> 4 weeks) the function of the overflow valve must be tested again.

## 6 Transportation, storage

### 6.1 Dangers during transportation



**The following safety instructions must be observed:**

- Have all work only carried out by authorized transport personnel.
- Use intact and correctly dimensioned hoisting equipment.
- Ensure that the means of transport is in a flawless state.
- Ensure that the centre of gravity of the load is taken into consideration.
- Do not stand under raised loads.

### 6.2 Dangers during storage



**The following safety instructions must be observed:**

- Observe the storage conditions.

### 6.3 Unpacking and checking the state of delivery

Personnel qualification:	<input type="checkbox"/> Trained personnel
--------------------------	--

1. ➤ Upon delivery check the pump/pump unit for damage during transportation.
2. ➤ Report damage during transportation immediately to the manufacturer.
3. ➤ Dispose of packaging material in accordance with the locally applicable regulations.

### 6.4 Transporting the pump/pump unit

Personnel qualification:	<input type="checkbox"/> Transport personnel
--------------------------	--

Personal protective equipment:	<input type="checkbox"/> Work clothing
	<input type="checkbox"/> Protective helmet
	<input type="checkbox"/> Protective gloves
	<input type="checkbox"/> Safety boots

Aids:	<input type="checkbox"/> Mobile crane, forklift, hoisting equipment
-------	---



## WARNING

### Risk of injury and damage to equipment through falling and toppling parts.

- ▶ Use intact and correctly dimensioned hoisting equipment in accordance with the total weight to be transported.
- ▶ Select the lift points for the hoisting equipment in accordance with the centre of gravity and the weight distribution.
- ▶ Use at least two load ropes.
- ▶ In the case of vertical transportation secure the motor against tipping.
- ▶ Do not stand under raised loads.

### ATTENTION

#### Damage to equipment through improper transportation.

- ▶ Protect the pump against damage, heat, sunlight, dust and moisture.

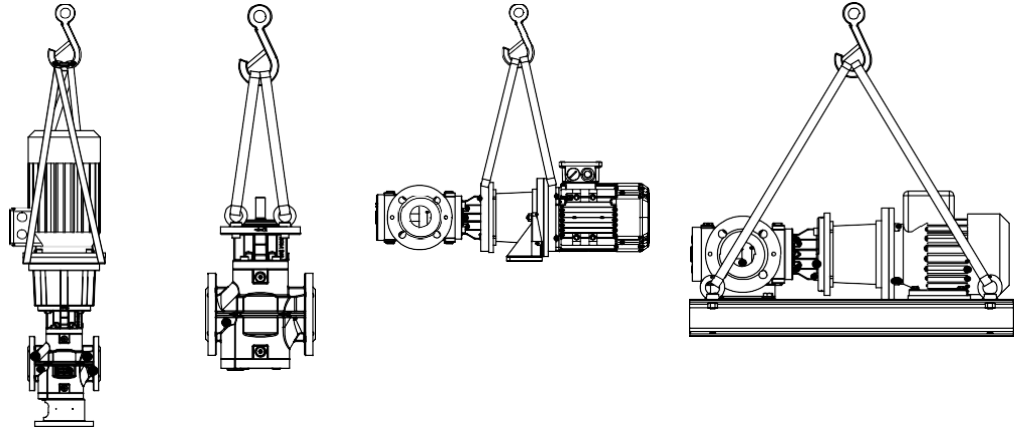

Fig. 6: Fastening of hoisting equipment - principle diagrams

1. ▶ Attach the hoisting equipment to the pump/pump unit and tighten. Ensure that the centre of gravity lies exactly under the crane hook.
2. ▶ Lift the pump/pump unit carefully and put it down shock-free.
3. ▶ Before loosening the transport belts ensure that the pump/pump unit is secured against tilting.

### 6.5 Storing the pump

During the test run, the internal components of the pump are wetted with test oil, which has a preservative effect. Pressure connection and suction connection are closed with protective caps. Unless otherwise specified, the outer surfaces of the pump are preserved with a single-coat PU-based two-component paint.

The preservative applied at the factory will protect the pump for about six weeks, if it is stored in a dry and clean location.

The manufacturer offers a long-term preservation for storage times of up to 60 months. The pump is additionally packed in hermetically sealing anti-corrosion paper.

Personnel qualification:	<input type="checkbox"/> Transport personnel
Aids:	<input type="checkbox"/> Mobile crane, forklift, hoisting equipment

### ATTENTION

#### Damage to equipment and corrosion if stored improperly and during longer standstills.

- ▶ Protect the pump against damage, heat, sunlight, dust and moisture.
- ▶ Protect against corrosion during longer standstill.
- ▶ Observe measures for storing and preservation.

1. ▶ Store cool and dry and protect against sunlight.
2. ▶ Ensure that the anti-corrosion paper is not damaged.
3. ▶ Observe the intervals for preservation ↪ Preservation, Page 14.

## 7.1 Preservation table

### 7 Preservation

#### 7.1 Preservation table

Preservation has to be carried out additionally under the following conditions:

Type of delivery	Condition
Standard delivery	<input type="checkbox"/> Storage time exceeding six weeks <input type="checkbox"/> Unfavourable storage conditions such as high humidity, salty air, etc.
Delivery with long-term preservation	<input type="checkbox"/> Opened or damaged packaging

Tab. 7: Conditions for additional preservation

#### 7.2 Preserving the inner surfaces

Personnel qualification:	<input type="checkbox"/> Trained personnel
Personal protective equipment:	<input type="checkbox"/> Work clothing <input type="checkbox"/> Protective gloves <input type="checkbox"/> Safety boots
Aids:	<input type="checkbox"/> Preservative (acid-free and resin-free oil)

1. ➤ Open the packaging carefully. If the pump is protected additionally by anti-corrosion paper, ensure that it is not damaged.
2. ➤ Close the suction connection of the pump with a blind flange.
3. ➤ Pour the preservative into the pressure connection until it reaches approx. 2 cm under the rim, while slowly turning the main screw against the direction of rotation.
4. ➤ Close the pressure connection of the pump with a new blind flange.
5. ➤ Close the packaging carefully.
6. ➤ After about six months storage check the filling level of the preservative and if necessary top up.

#### 7.3 Preserving the outer surfaces

Personnel qualification:	<input type="checkbox"/> Trained personnel
Personal protective equipment:	<input type="checkbox"/> Work clothing <input type="checkbox"/> Face protection <input type="checkbox"/> Protective gloves <input type="checkbox"/> Safety boots
Aids:	<input type="checkbox"/> Calcium complex grease (for example TEVI-ER® GREASE WAVE 100 with adhesive additive) <input type="checkbox"/> Castrol Rustilo DWX 33 or other preservative offering comparable protection

1. ➤ Brush calcium complex grease corrosion protection (for example TEVI-ER® FETT WAVE 100 with adhesive additive) to the mounting surfaces.
2. ➤ Brush or spray preservative (for example Castrol Rustilo DWX 33) onto the process connections and remaining plain and unpainted parts.
3. ➤ At intervals of about six months check the preservation and if necessary repeat.

#### 7.4 Removing the preservation

Personnel qualification:	<input type="checkbox"/> Trained personnel
Personal protective equipment:	<input type="checkbox"/> Work clothing <input type="checkbox"/> Face protection <input type="checkbox"/> Protective gloves <input type="checkbox"/> Safety boots
Aids:	<input type="checkbox"/> Solvent <input type="checkbox"/> Collection tank <input type="checkbox"/> Steam-jet cleaning device with wax-dissolving additives



### CAUTION

#### Risk of injury through discharging preservative.

- ▶ Wear personal protective equipment during all the work.
- ▶ Collect any discharging preservative safely and dispose of it in an environmentally compatible manner in accordance with the applicable local regulations.

1. ▶ Clean the outside of the pump with solvents, if necessary using a steam-jet cleaning device.
2. ▶ Remove the pressure-side blind flange carefully in order to reduce any pressure that may exist in the pump.
3. ▶ Drain the pump, collecting the preservative in a suitable vessel.
4. ▶ Remove the blind flange on the suction side.
5. ▶ To remove the residual preservative, flush the pump with the pumped liquid.

## 8 Installation, removal

### 8.1 Dangers during installation



#### The following safety instructions must be observed strictly:

- Have all work carried out only by authorized qualified personnel.
- Before installation ensure that the operating limits, NPSH values and ambient conditions are observed.
- Observe the tightening torques ↪ Appendix, Page 56.
- Ensure that all the components can be accessed and that maintenance work can be carried out easily.

### 8.2 Dangers during removing



#### The following safety instructions must be observed strictly:

- Have all work carried out only by authorized qualified personnel.
- Before beginning work, let the pump unit cool down to the ambient temperature.
- Collect any discharging pumped liquid safely and dispose of it in an environmentally compatible manner in accordance with the applicable local regulations.
- Ensure that the collection tank for discharging pumped liquid is sufficiently large.

### 8.3 Installing the pump

The pumps can be operated in horizontal and vertical installation position.

**Note** Soiling in the pipe system impair the service life of the pump. If the pipe system is flushed using the pump during the initial commissioning, an additional commissioning filter has to be installed temporarily before the pump at the system (mesh width: 0.02 mm).

Personnel qualification:	<input type="checkbox"/> Transport personnel <input type="checkbox"/> Fitter
Personal protective equipment:	<input type="checkbox"/> Work clothing <input type="checkbox"/> Protective helmet <input type="checkbox"/> Protective gloves <input type="checkbox"/> Safety boots
Aids:	<input type="checkbox"/> Mobile crane, forklift, hoisting equipment



### WARNING

#### Risk of injury and damage to equipment through falling and toppling parts.

- ▶ Only fasten the pump on a stable load-bearing underground or stable load-bearing load support.
- ▶ Ensure that fastening elements and pipings are fastened sufficiently.

### ATTENTION

#### Damage to motor through discharging pumped liquid.

- ▶ Do not install the pump above the motor.

### ATTENTION

#### Damage to device through impurity in the pipe system.

- ▶ During welding work attach protective covers in front of the connecting flanges.
- ▶ Ensure when welding that welding beads and abrasive dust cannot get into the pipe system and the pump.
- ▶ Ensure that a commissioning filter is installed when the pipe system is flushed and cleaned using the pump.

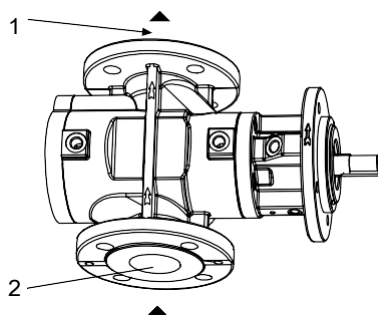

- 1 Pressure connection
- 2 Suction connection

Fig. 7: Flow direction

#### Requirement:

- ✓ Pump protection: Integrated overflow valve or system-side overflow valve/safety valve installed.
  - ✓ Pump connections protected against soiling, for example by using the protective cover mounted in the factory
  - ✓ If required, hoisting equipment prepared
- ▶ Bring the pump in the installation position, while observing the position of the motor and the arrows for the flow direction on the pump housing (1 pressure connection, 2 suction connection).
  - ▶ Fasten the pump with fastening elements securely on the underground.

## 8.4 Removing the pump

Personnel qualification:	<input type="checkbox"/> Transport personnel <input type="checkbox"/> Fitter <input type="checkbox"/> Electrician
Personal protective equipment:	<input type="checkbox"/> Work clothing <input type="checkbox"/> Protective helmet <input type="checkbox"/> Face protection <input type="checkbox"/> Protective gloves <input type="checkbox"/> Safety boots
Aids:	<input type="checkbox"/> Mobile crane, forklift, hoisting equipment <input type="checkbox"/> Collection tank



### DANGER

#### Risk of death resulting from electric shock.

- ▶ Ensure that the electrical power supply is de-energized and is secured against being switched back on.
- ▶ Observe the operating instructions of the electrical components.





### DANGER

#### Risk of death through emitted pumped liquid.

Pumped liquids can be hot, poisonous, combustible and caustic and can spray out under high pressure.

- ▶ Wear personal protective clothing during all the work. Ensure face protection.
- ▶ Before beginning work, let the pump unit cool down to the ambient temperature.
- ▶ Ensure that the pump is depressurized.
- ▶ Collect any discharging pumped liquid safely and dispose of it in an environmentally compatible manner in accordance with the applicable local regulations.

#### Requirement:

- ✓ Pump unit cooled down to the ambient temperature
  - ✓ Pump unit disconnected from the electrical power supply, deenergized and secured against being switched back on
1. ➤ Close the pressure-side and suction-side shut-off devices.
  2. ➤ Empty the pump at the lowest point. Collect the discharging pumped liquid in a collection tank.
  3. ➤ Dismantle the pressure-side and suction-side connecting flanges.
  4. ➤ Disconnect the pump unit from the pipe system and empty it. Collect any discharging pumped liquid.
  5. ➤ Screw out the fastening elements used to fasten the pump.
  6. ➤ Dismantle the pump unit on site or transport it to a suitable location ↪ Transportation, storage, Page 12.

## 9 Connection

### 9.1 Dangers during connection work



#### The following safety instructions must be observed strictly:

- Have all work on the pump and pipe system only carried out by authorized qualified personnel.
- Ensure that impurities cannot get into the pump and pipe system.
- Ensure that mechanical connections are mounted stress-free.
- Observe the tightening torques ↪ Appendix, Page 56.
- Have all the work on the electrical equipment only carried out by electricians.
- Before beginning work on the pump ensure that the electrical power supply is deenergized and is secured against being switched back on.
- If the insulation of the electrical cables or wires is damaged, disconnect the power supply immediately.

### 9.2 Connecting the pump to the pipe system

Personnel qualification:	<input type="checkbox"/> Transport personnel <input type="checkbox"/> Fitter
Personal protective equipment:	<input type="checkbox"/> Work clothing <input type="checkbox"/> Protective gloves <input type="checkbox"/> Protective helmet <input type="checkbox"/> Safety boots
Aids:	<input type="checkbox"/> Mobile crane, forklift, hoisting equipment

## 9.3 Insulating the pump

### ATTENTION

#### Damage to device through impurity in the pipe system.

- ▶ During welding work attach protective covers in front of the connecting flanges.
- ▶ Ensure when welding that welding beads and abrasive dust cannot get into the pipe system and the pump.
- ▶ Ensure that a commissioning filter is installed when the pipe system is flushed and cleaned using the pump.

### ATTENTION

#### Damage to device through mechanical stress.

- ▶ Ensure that the pump is mounted free of mechanical stresses in the pipe system.
- ▶ Observe the tightening torques.

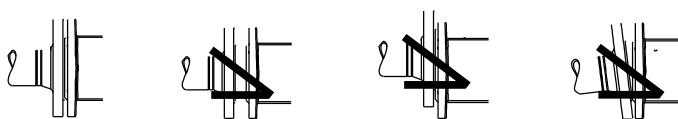

Fig. 8: Connection to pipe system

1. ▶ Turn the pump shaft or the fan impeller of the motor. This tests that the pump runs smoothly. If the pump shaft cannot be turned by hand, remedy the fault before installing the pump ↪ Troubleshooting, Page 36.
2. ▶ Before carrying out welding work mount a protective cover on the suction connection and pressure connection.
3. ▶ Place the piping in position and support the weight of the piping.
4. ▶ Check the linear, height and angular offset and correct if necessary.  
⇒ If the screws tighten easily, this is a sure sign that the installation is stress-free.
5. ▶ Tighten the connecting screws crosswise with torque, Table of tightening torques ↪ Appendix, Page 56.

## 9.3 Insulating the pump

Personnel qualification:	<input type="checkbox"/> Fitter
Personal protective equipment:	<input type="checkbox"/> Work clothing <input type="checkbox"/> Protective gloves <input type="checkbox"/> Safety boots
Aids:	<input type="checkbox"/> Insulation material



### WARNING

#### Hot surface.

Touching of uninsulated hot surfaces results in burns.

- ▶ Insulate components and pipings in which hot liquids (> 60 °C) flow before commissioning.

—▶ Before commissioning, carefully insulate all potentially hot surfaces of the pump and the connected piping or provide suitable protection against accidental contact.

## 9.4 Assembling the pump and motor

Personnel qualification:	<input type="checkbox"/> Fitter
Personal protective equipment:	<input type="checkbox"/> Work clothing <input type="checkbox"/> Protective gloves <input type="checkbox"/> Safety boots

### ATTENTION

**Damage to coupling and bearing through incorrect alignment of the coupling.**

- ▶ To guarantee a long service life of the coupling, align shaft ends exactly.
- ▶ After assembly check permissible displacement figures of the coupling according to table below.

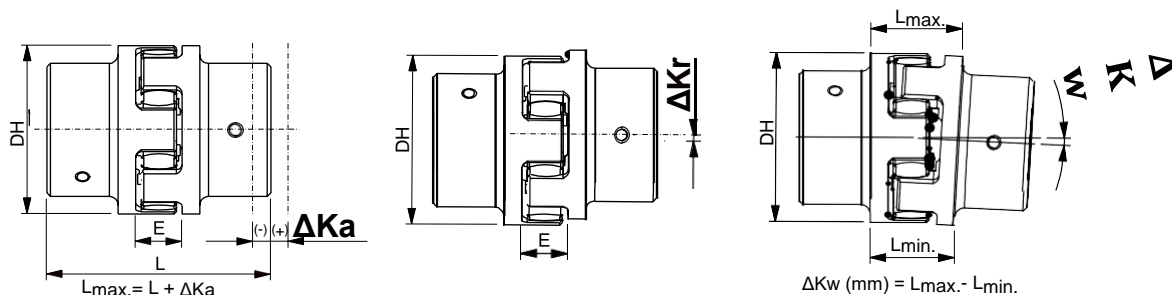

Fig. 9: Coupling alignment measuring points

Outer diameter DH [mm]	Coupling distance E [mm]	Max. axial displacement $\Delta K_a$ [mm]	Max. radial displacement $\Delta K_r$ [mm]	Max. angular displacement $\Delta K_w$ [°]	[mm]
30	13	-0.5/ +1.0	0.17	1.2	0.7
40	16	-0.5/ +1.2	0.20	1.2	0.8
55	18	-0.5/ +1.4	0.22	0.9	0.9
65	20	-0.7/ +1.5	0.25	0.9	1.1
80	24	-0.7/ +1.8	0.28	1.0	1.4
95	26	-1.0/ +2.0	0.32	1.0	1.7
105	28	-1.0/ +2.1	0.36	1.1	2.0
120	30	-1.0/ +2.2	0.38	1.1	2.3
135	35	-1.0/ +2.6	0.42	1.2	2.7
160	40	-1.5/ +3.0	0.48	1.2	3.3

Tab. 8: Limit values for aligning the shaft coupling

1. ▶ Check the radial displacement  $\Delta K_r$  of the coupling using a hairline gauge and feeler gauge. Check several points along the periphery of the coupling.
2. ▶ Check the angular displacement  $\Delta K_w$  of the coupling using a hairline gauge.
3. ▶ Check the axial displacement  $\Delta K_a$  of the coupling using a slide gauge or feeler gauge.
4. ▶ If the limit values of the above table are exceeded, loosen the fastening of the pump or motor and move pump or motor in order to reduce the respective offset.

### 9.5 Connecting the pump unit to the power supply

Personnel qualification:	<input type="checkbox"/> Electrician
Aids:	<input type="checkbox"/> Operating instructions of the motor <input type="checkbox"/> Motor circuit diagram



### DANGER

**Risk of death resulting from electric shock.**

- ▶ Ensure that the electrical power supply is de-energized and is secured against being switched back on.
- ▶ Before commissioning ensure correct grounding and equipotential bonding.
- ▶ Observe the operating instructions of the electrical components.

## 10.1 Dangers during operation

1. ➤ Ensure that the operating data on the rating plate of the motor agree with the operating data of the pump and with the local power supply.
2. ➤ Carefully earth the pump bracket foot, base frame or pedestal via the screwing.
3. ➤ Connect the motor in accordance with the operating instructions and circuit diagram in the motor terminal block.
4. ➤ When connecting the pump unit to the complete system continue equipotential bonding.

## 10 Operation

### 10.1 Dangers during operation



**The following safety instructions must be observed strictly:**

- Have all work carried out only by authorized qualified personnel.
- Before commissioning ensure that a safety valve has been installed in the pipe system on the pressure side before the first shut-off device.
- Before commissioning, make sure that the suction line and pump are filled.
- Pumped liquids can be hot, poisonous, combustible and caustic. Use corresponding protective equipment.
- Ensure that the pump station is only operated within the operating limits.
- Wear hearing protection if you work for a longer time directly at the pump.
- Ensure that the maximum permissible system pressure is not exceeded.
- Ensure that during cooling down or heating up the pump is only subjected to slow temperature changes.
- Ensure that existing safety equipment is not bypassed or activated during operation.
- Before decommissioning ensure that the electrical power supply is deenergized and is secured against being switched back on.

### 10.2 Commissioning

#### 10.2.1 Cleaning the pipe system

**Note** Soiling in the pipe system impair the service life of the pump. If the pipe system is flushed using the pump during the initial commissioning, an additional commissioning filter has to be installed temporarily before the pump at the system.

Personnel qualification:	<input type="checkbox"/> Fitter
Personal protective equipment:	<input type="checkbox"/> Work clothing <input type="checkbox"/> Protective gloves <input type="checkbox"/> Safety boots

### ATTENTION

**Damage to equipment through additional pressure loss in the commissioning filter/commissioning strainer.**

- ▶ Calculate the flow resistance and determine the remaining pump intake.
- ▶ Monitor the suction-side pressure.
- ▶ Check the commissioning filter/commissioning strainer regularly.

Requirement:

✓ If required, commissioning filter installed (mesh width 0.02 mm)

1. ➤ Clean the complete pipe system before commissioning in order to protect the pump.
2. ➤ Flush the pipe system at least 50 – 100 hours.

#### 10.2.2 Filling and venting the pump

##### Possibilities

There are two possible ways to fill the pump:

- Via the suction connection or pressure connection
- Via the vent holes

## Filling and venting the pump via the suction connection or pressure connection

Personnel qualification:	<input type="checkbox"/> Fitter
Personal protective equipment:	<input type="checkbox"/> Work clothing <input type="checkbox"/> Face protection <input type="checkbox"/> Protective gloves <input type="checkbox"/> Safety boots



### DANGER

#### Risk of death through discharging pumped liquid.

Pumped liquids can be hot, poisonous, combustible and caustic and can spray out under high pressure.

- ▶ Wear personal protective equipment during all the work. Ensure face protection.
- ▶ Collect any discharging pumped liquid safely and dispose of it in an environmentally compatible manner in accordance with the applicable local regulations.

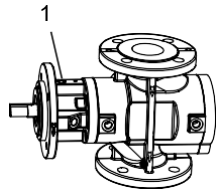

1 Sealing chamber vent hole

1. ▶ Open the screw plug of the vent hole 1 by a maximum of 2 rotations so that air can escape during the filling process.
2. ▶ Open the suction-side or pressure-side shut-off device and fill the pump via the suction connection or pressure connection until pumped liquid is emitted at the vent hole 1.
3. ▶ While filling, turn the pump shaft or the motor fan impeller manually in order to speed up the filling process:  
 Filling via suction connection: Turn the pump shaft in the direction of the arrow on the pump flange.  
 Filling via pressure connection: Turn the pump shaft against the direction of the arrow on the pump flange.
4. ▶ Retighten the screw plug of the vent hole 1.

## Filling and venting the pump via the vent hole

Personnel qualification:	<input type="checkbox"/> Fitter
Personal protective equipment:	<input type="checkbox"/> Work clothing <input type="checkbox"/> Face protection <input type="checkbox"/> Protective gloves <input type="checkbox"/> Safety boots



### WARNING

#### Risk of injury through emitted pumped liquid.

Pumped liquids can be hot, poisonous, combustible and caustic.

- ▶ Wear personal protective clothing during all the work. Ensure face protection.
- ▶ Collect any discharging pumped liquid safely and dispose of it in an environmentally compatible manner in accordance with the applicable local regulations.

## 10.2 Commissioning

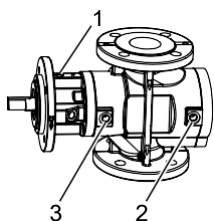

- 1 Sealing chamber vent hole
- 2 Suction-side vent hole
- 3 Pressure-side vent hole

Requirement:

- ✓ Shut-off devices in the suction line and pressure line closed
- 1. ➤ Remove the screw plug of the vent hole 1 so that the air can escape during the filling process.
- 2. ➤ Remove the screw plug of the pressure-side vent hole 3.
- 3. ➤ Fill the pump via the pressure-side vent hole 3 until the pumped liquid is emitted from the vent hole 1.
- 4. ➤ While filling, turn the pump shaft or the motor fan impeller manually in order to speed up the filling process:
  - Filling the suction chamber: Turn the pump shaft against the direction of the arrow on the pump flange.
  - Filling the sealing chamber: Turn the pump shaft in the direction of the arrow on the pump flange. To speed up the filling of the sealing chamber, fill the sealing chamber of the pump via the vent hole 1 until pumped liquid is emitted.
- 5. ➤ Retighten the screw plug of the pressure-side vent hole 3.
- 6. ➤ Retighten the screw plug of the vent hole 1.

### 10.2.3 Checking the direction of rotation

The direction of rotation is indicated by an arrow on the pump flange/pump housing. The direction of rotation of the motor specifies the direction of rotation of the pump. The fan impeller of the motor must rotate in the same direction in which the arrow for the direction of rotation on the pump flange points.

**Note** Standard direction of rotation: clockwise (viewed from the motor)

Personnel qualification:	<input type="checkbox"/> Fitter
--------------------------	---------------------------------

### ATTENTION

**Dry running can damage pump equipment.**

- ▶ Ensure that the pump is filled properly.
- ▶ Switch the pump on for a maximum of one second and then off again immediately.

- 1. ➤ Switch on the power supply and then turn it off again immediately.

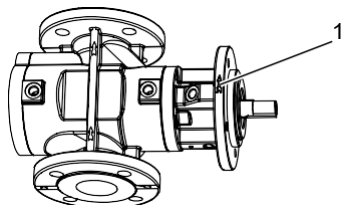

- 2. ➤ Compare the direction of rotation of the fan impeller with the arrow for the direction of rotation 1.
- 3. ➤ If the directions do not match, swap the two electrical connection phases. Repeat Steps 1 and 2.

### 10.2.4 Commissioning the pump

Personnel qualification:	<input type="checkbox"/> Fitter <input type="checkbox"/> Electrician
Personal protective equipment:	<input type="checkbox"/> Work clothing <input type="checkbox"/> Face protection <input type="checkbox"/> Protective gloves <input type="checkbox"/> Safety boots
Aids:	<input type="checkbox"/> Collection tank



## DANGER

### Risk of death resulting from bursting components and discharging pumped liquid.

As a result of impermissibly high pressure, components can burst with high energy, for example through the pressure-side pipe system being shut off.

- ▶ Wear personal protective equipment during all the work.
- ▶ System protection: Before carrying out commissioning ensure that a safety valve is installed in the pressure-side pipe system at the system end.
- ▶ Pump protection: Ensure before commissioning that an integrated overflow valve or system-side overflow valve/safety valve is installed.



## WARNING

### Risk of injury through emitted pumped liquid.

Pumped liquids can be hot, poisonous, combustible and caustic.

- ▶ Wear personal protective clothing during all the work. Ensure face protection.
- ▶ Collect any discharging pumped liquid safely and dispose of it in an environmentally compatible manner in accordance with the applicable local regulations.



## WARNING

### Hot surface.

Touching of uninsulated hot surfaces results in burns.

- ▶ Insulate components and pipings in which hot liquids (> 60 °C) flow before commissioning.



## WARNING

### Danger of injury through rotating parts.

- ▶ Ensure that the coupling protection is mounted.

## ATTENTION

### Dry running can damage pump equipment.

- ▶ Ensure that the pump and the connected pipe system are filled properly.
- ▶ If the pump does not deliver after 10 – 15 seconds, abort commissioning.

Requirement:

- ✓ Pump unit set up correctly
- ✓ Coupling aligned correctly ↪ Connection, Page 17
- ✓ Connections connected sealingly
- ✓ Motor connected correctly
- ✓ Pipe system is free of impurities
- ✓ System protection: Safety valve in accordance with EN ISO 4126-1 installed in the pressure-side pipe system before the first shut-off device
- ✓ Pump protection: Integrated overflow valve or system-side overflow valve/safety valve installed.
- ✓ Pump filled with pumped liquid
- ✓ Shut-off devices in the suction line and pressure line opened

1. ▶ Switch on the pump unit.
  - ⇒ The pump delivers when the pressure on the pressure side of the pump rises or a flow indicator at the system side triggers.
2. ▶ If the pump does not deliver after 10 – 15 seconds of operation, abort commissioning. Eliminate the cause for the fault and only then continue with commissioning. Take the information from the fault table into account ↪ Troubleshooting, Page 36.
3. ▶ Run the pump for a few minutes to allow the pipe system to vent fully.

## 10.3 During operation

⇒ The pipe system is fully vented when the pump operating noise is smooth and a pressure gauge on the pressure side shows no more fluctuations.

1. ➤ Checking overflow valve functions ↪ During operation, Page 24.

### 10.3 During operation

#### 10.3.1 Checking the operating pressure

Personnel qualification:  Trained personnel

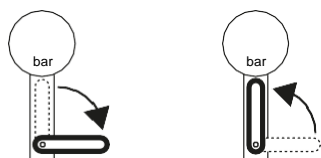

Fig. 10: Pressure gauge shut-off valves closed/open - principle diagram

### ATTENTION

**Leak in the pressure gauge through permanently opened pressure gauge shut-off valve.**

- ▶ Close the pressure gauge shut-off valve immediately after completing reading.

1. ➤ Open the pressure gauge shut-off valve.
2. ➤ Read the operating pressure and close the pressure gauge shut-off valve.

#### 10.3.2 Monitoring the filter and/or strainer

**Note** The manufacturer recommends protecting the pump against soiling by means of a filter and/or strainer installed at the system end (mesh width 0.5 mm). The degree of soiling of the filter and/or the strainer can be monitored by means of a suction-side pressure gauge or a differential pressure indicator.

Personnel qualification:  Trained personnel

1. ➤ After commissioning monitor the degree of soiling of the filter and/or strainer by means of a suction-side pressure gauge or a differential pressure indication.
2. ➤ Also check the filters/strainers in the event of a pressure drop on the suction side. Observe the dimensioning data of the manufacturer of the filters and/or strainers.
3. ➤ Check the suction-side pressure every two weeks during operation.
4. ➤ Regularly check the magnetic separator in the filter/strainer during operation and clean it if necessary.

#### 10.3.3 Adjusting the overflow valve

Personnel qualification:  Fitter

Aids:  Allen key

**Note** The opening pressure of the overflow valve is set to 110% of the differential pressure in the factory.

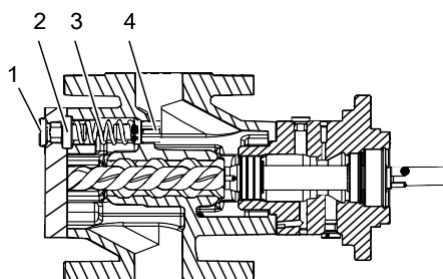

- 1 Screw plug
- 2 Adjusting screw
- 3 Pressure spring
- 4 Valve body

Fig. 11: Overflow valve





## WARNING

### Risk of injury through emitted pumped liquid.

Pumped liquids can be hot, poisonous, combustible and caustic.

- ▶ Wear personal protective clothing during all the work. Ensure face protection.
- ▶ Collect any discharging pumped liquid safely and dispose of it in an environmentally compatible manner in accordance with the applicable local regulations.

Requirement:

✓ Pressure-side pressure gauge installed

1. ▶ Switch on the pump unit and remove the screw plug **1** of the overflow valve.
2. ▶ Increase the supply pressure step-by-step to check the opening pressure of the overflow valve. Keep an eye on the pressure gauge and make sure that the operating limits are observed.
  - ⇒ The opening pressure is reached, when the displayed pressure falls.
3. ▶ Turn the adjusting screw **2** to set the opening pressure:
  - Turning clockwise: Increase the opening pressure
  - Turning counter-clockwise: Reduce the opening pressure
4. ▶ Repeat Steps 2 and 3 until the desired opening pressure is reached.
5. ▶ Tighten the screw plug **1** again.

#### 10.3.4 Test the overflow valve

Personnel qualification:	<input type="checkbox"/> Trained personnel
Personal protective equipment:	<input type="checkbox"/> Work clothing <input type="checkbox"/> Face protection <input type="checkbox"/> Protective gloves <input type="checkbox"/> Safety boots



## WARNING

### Risk of injury through emitted pumped liquid.

Pumped liquids can be hot, poisonous, combustible and caustic.

- ▶ Wear personal protective clothing during all the work. Ensure face protection.
- ▶ Collect any discharging pumped liquid safely and dispose of it in an environmentally compatible manner in accordance with the applicable local regulations.

Requirement:

- ✓ Function test necessary ↪ Maintenance, Page 27
- ✓ Pressure-side pressure gauge installed

1. ▶ Switch on the pump unit.
2. ▶ Gradually increase the delivery pressure downstream of the pump using a valve/ball valve etc. Keep an eye on the pressure gauge and make sure that the operating limits are observed.
  - ⇒ The response pressure of the overflow valve is reached as soon as the displayed pressure drops briefly.
  - ⇒ Flow noises change.
  - ⇒ Overflow valve opens and closes at short intervals.
3. ▶ Close the valve/ball valve downstream of the pump completely.
  - ⇒ 100% of the delivery volume now circulates via the overflow valve.
4. ▶ Keep an eye on the pressure gauge and make sure that the operating limits are observed.
5. ▶ Maintain the operating state for a maximum of 30 s.
6. ▶ Open the valve/ball valve completely again after the pump.
7. ▶ Switch off the pump unit.

## 10.4 Decommissioning

### 10.3.5 Switching off the pump unit

Personnel qualification:	<input type="checkbox"/> Trained personnel
--------------------------	--

### ATTENTION

#### Seal damage through pressurizing during standstill.

- ▶ Ensure that the maximum permissible system pressure is not exceeded.

- ▶ Switch off the motor.
- ▶ Close the pressure-side shut-off device.

## 10.4 Decommissioning

### 10.4.1 Decommissioning the pump

Decommissioning is an operation interruption that requires different measures depending on the scope and duration of the interruption as well as the properties of the pumped liquid.

Personnel qualification:	<input type="checkbox"/> Fitter <input type="checkbox"/> Electrician
Personal protective equipment:	<input type="checkbox"/> Work clothing <input type="checkbox"/> Protective gloves <input type="checkbox"/> Safety boots
Aids:	<input type="checkbox"/> Collection tank



### WARNING

#### Risk of injury through emitted pumped liquid.

Pumped liquids can be hot, poisonous, combustible and caustic.

- ▶ Wear personal protective clothing during all the work. Ensure face protection.
- ▶ Collect any discharging pumped liquid safely and dispose of it in an environmentally compatible manner in accordance with the applicable local regulations.

### ATTENTION

#### Damage to equipment through excessively fast temperature change.

- ▶ Subject the pump only to slow temperature changes.
- ▶ Under no circumstances heat the pump with an open flame.

▶ Carry out the following measures during operation interruptions:

Scope of the operation interruption	Measure
<input type="checkbox"/> Shutting down the pump for a longer period	Depending on the pumped liquid
<input type="checkbox"/> Draining the pump	Close the pressure-side and suction-side shut-off devices.
<input type="checkbox"/> Dismantling the pump	Disconnect the motors from the power supply and secure against being switched back on.
<input type="checkbox"/> Storing the pump	Observe measures for storing and preservation ↪ Transportation, storage, Page 12.

Tab. 9: Measures during operation interruptions

Behaviour of the pumped liquid	Duration of the operation interruption	
	Short	Long
<input type="checkbox"/> Solids sediment	Rinse the pump.	Rinse the pump.
<input type="checkbox"/> Congealed/frozen <input type="checkbox"/> No corrosive burden	Heat or drain the pump.	Drain the pump.
<input type="checkbox"/> Congealed/frozen <input type="checkbox"/> Corrosive burden	Heat or drain the pump.	1. Drain the pump. 2. Preserve the pump.
<input type="checkbox"/> Remains liquid <input type="checkbox"/> No corrosive burden	–	–
<input type="checkbox"/> Remains liquid <input type="checkbox"/> Corrosive burden	–	1. Drain the pump. 2. Preserve the pump.

Tab. 10: Measures depending on the behaviour of the pumped liquid

→ Drain the pump via the pressure line, suction line, vent screws and screw plugs.

## 10.5 Recommissioning

### 10.5.1 Recommissioning the pump

→ Depending on the extent and duration of the interruption of operation, carry out steps as for commissioning ↪ Commissioning, Page 20.

## 11 Maintenance

### 11.1 Dangers during maintenance



The following safety instructions must be observed strictly:

- Have all work carried out only by authorized qualified personnel.
- Before beginning work, let the pump unit cool down slowly to the ambient temperature. Avoid rapid temperature changes.
- Pumped liquids can be hot, poisonous, combustible and caustic. Use corresponding protective equipment.
- Collect any discharging pumped liquid safely and dispose of it in an environmentally compatible manner in accordance with the applicable local regulations.
- Ensure that the collection tank for discharging pumped liquid is sufficiently large.
- Observe the operating instructions and data sheets of the components.

### 11.2 Required maintenance

The service life depends on the observance of the operating conditions of the pump and the requirements from the operating instructions of the components.

Component	Required maintenance	Cycle
Leakage vent hole	<input type="checkbox"/> Visual inspection <input type="checkbox"/> If required, clean	4 weeks
Filter/strainer (system side)	<input type="checkbox"/> Check of the suction-side pressure	2 weeks
Overflow valve	<input type="checkbox"/> Function test	≤ 5 years

Tab. 11: Required maintenance

### 11.3 Ball bearing

The ball bearings used are lifetime lubricated. Maintenance is therefore not required. The manufacturer recommends renewing the ball bearings every 20,000 operating hours.

## 11.4 Maintaining the pump

### 11.4 Maintaining the pump

Personnel qualification:	<input type="checkbox"/> Fitter
Personal protective equipment:	<input type="checkbox"/> Work clothing <input type="checkbox"/> Protective gloves <input type="checkbox"/> Safety boots <input type="checkbox"/> Face protection



### WARNING

#### Risk of injury through emitted pumped liquid.

Pumped liquids can be hot, poisonous, combustible and caustic.

- ▶ Wear personal protective clothing during all the work. Ensure face protection.
- ▶ Collect any discharging pumped liquid safely and dispose of it in an environmentally compatible manner in accordance with the applicable local regulations.

1. ▶ Check the pump visually and acoustically every four weeks.
2. ▶ If there are signs of wear, eliminate the cause ↪ Servicing, Page 28.

### 11.5 Cleaning the leakage vent hole

The regular small amounts of leakage can result in deposits that can prevent free draining of further leakage liquids after a longer operating period.

Personnel qualification:	<input type="checkbox"/> Fitter
Personal protective equipment:	<input type="checkbox"/> Work clothing <input type="checkbox"/> Face protection <input type="checkbox"/> Protective gloves <input type="checkbox"/> Safety boots

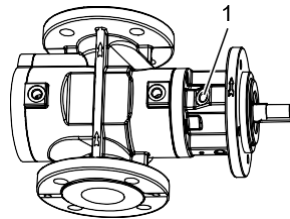

1. ▶ If a leakage vent line is connected, unscrew the leakage vent line.
2. ▶ To check the permeability of the leakage vent hole **1** insert a flexible soft arbour into the leakage vent hole.
3. ▶ In case of insufficient permeability clean the leakage vent hole and if existing the leakage vent line.
4. ▶ If existing, reconnect the leakage vent line again.

## 12 Servicing

### 12.2 Dangers during servicing



**The following safety instructions must be observed strictly:**

- Have all work carried out only by authorized qualified personnel.
- Before beginning work on the pump ensure that the electrical power supply is deenergized and is secured against being switched back on.
- Before beginning work, let the pump unit cool down slowly to the ambient temperature. Avoid rapid temperature changes.
- Pumped liquids can be hot, poisonous, combustible and caustic. Use corresponding protective equipment.
- Ensure that the pump is depressurized and that shut-off devices are not operated uncontrolled.
- Collect any discharging pumped liquid safely and dispose of it in an environmentally compatible manner in accordance with the applicable local regulations.
- Ensure that the collection tank for discharging pumped liquid is sufficiently large.
- Observe the tightening torques ↗ Appendix, Page 56.
- Observe the operating instructions and data sheets of the components.

### 12.3 Wear

#### 12.3.1 Signs of wear

The following table lists signs of progressive wear of individual pump elements:

Finding	Cause	Elimination
Increased running noises	Incipient damage to bearing	Replace the ball bearing.
Increased leaking	Incipient damage to seal	Replace the shaft seal.
Increased play in the coupling	Advanced wear of the coupling intermediate ring	Replace coupling intermediate ring.
Reduction in the delivery rate or pressure under constant operating conditions	Advanced wear of screws and housing	Replace the pump.

Tab. 12: Signs of wear

#### 12.3.2 Radial shaft seal

Shaft seals are subject to natural wear that depends strongly on the respective conditions of use. General statements about the service life can therefore not be given.

### 12.4 Replacing the overflow valve

#### 12.4.1 Removing the overflow valve

Personnel qualification:	<input type="checkbox"/> Fitter
Personal protective equipment:	<input type="checkbox"/> Work clothing <input type="checkbox"/> Protective gloves <input type="checkbox"/> Safety boots

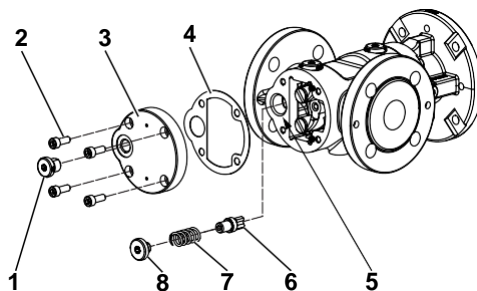

1. ➤ Remove the screw plug **1** and socket screws **2**.
2. ➤ Remove the end cover **3** and flat gasket **4** from the pump housing **5**.
3. ➤ Carefully screw out the adjusting screw **8** and remove the pressure spring **7** and valve body **6** from the pump housing.

## 12.5 Replacing the coupling

### 12.4.2 Installing the overflow valve

Personnel qualification:	<input type="checkbox"/> Fitter
Personal protective equipment:	<input type="checkbox"/> Work clothing <input type="checkbox"/> Protective gloves <input type="checkbox"/> Safety boots

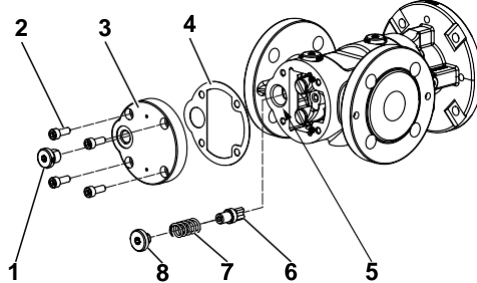

1. ➤ Clean the fitting surface carefully and bond a new flat gasket 4 to the fitting surface.
2. ➤ Insert the valve body 6, pressure spring 7 into the pump housing 5 and secure the pressure spring with the adjusting screw 8.
3. ➤ Position the end cover 3 and tighten the socket screws 2 with torque.
4. ➤ Set the overflow valve ↪ During operation, Page 24.

## 12.5 Replacing the coupling

### 12.5.1 Removing the coupling

Personnel qualification:	<input type="checkbox"/> Fitter
Personal protective equipment:	<input type="checkbox"/> Work clothing <input type="checkbox"/> Protective gloves <input type="checkbox"/> Safety boots
Aids:	<input type="checkbox"/> Extractor



### WARNING

#### Risk of injury and damage to equipment through falling and toppling parts.

- ▶ Use intact and correctly dimensioned hoisting equipment in accordance with the total weight to be transported.
- ▶ Select the lift points for the hoisting equipment in accordance with the centre of gravity and the weight distribution.
- ▶ Use at least two load ropes.
- ▶ In the case of vertical transportation secure the motor against tipping.
- ▶ Do not stand under raised loads.

#### Requirement:

- ✓ Pump unit disconnected from the electrical power supply, deenergized and secured against being switched back on

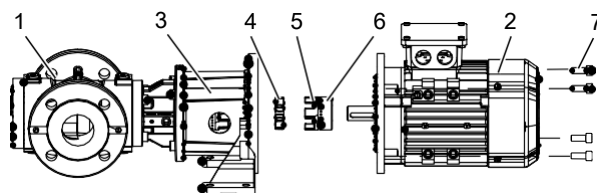

1. ➤ Remove the socket screws 7 between the motor 2 and pump bracket 3 and lift pump 1 with pump bracket from the motor.
2. ➤ Loosen the fixing screw 6 at the motor-side coupling half 5.
3. ➤ Remove the coupling intermediate ring 4 and pull off the coupling half 5 using an extractor.

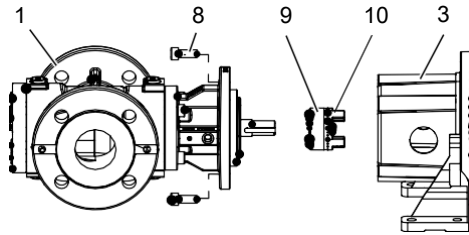

4. ➤ Remove the socket screws **8** between the pump **1** and pump bracket **3** and remove the pump bracket.
5. ➤ Loosen the fixing screw **9** at the pump-side coupling half **10** and pull off the coupling half using a suitable tool.

### 12.5.2 Installing the coupling

Personnel qualification:	<input type="checkbox"/> Fitter
Personal protective equipment:	<input type="checkbox"/> Work clothing <input type="checkbox"/> Protective gloves <input type="checkbox"/> Safety boots
Aids:	<input type="checkbox"/> Measuring stick <input type="checkbox"/> Silicone oil

**Note** The coupling halves can be mounted more easily if they are heated to 80 °C – 100 °C.

1. ➤ Oil the shaft of the pump with silicone oil.

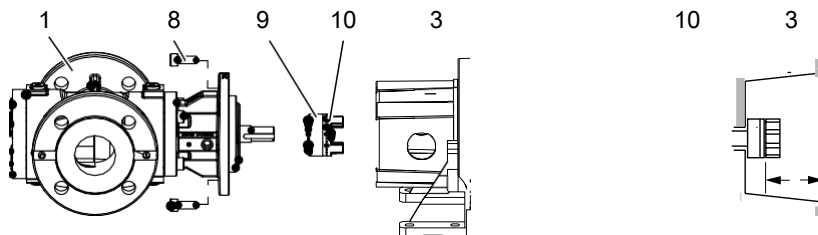

2. ➤ Slide the pump-side coupling half **10** onto the shaft until it stops.
3. ➤ Tighten the fixing screw **9** of the pump-side coupling half **10**.
4. ➤ Place the pump bracket **3** onto the pump **1** and tighten the socket screws **8** crosswise with torque.
5. ➤ Measure and write down the distance **X** between the face of the coupling claws and the connecting surface of the pump bracket **3**.

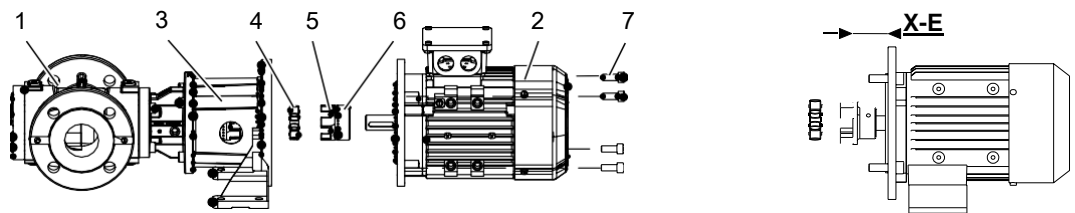

6. ➤ Tighten the motor-side coupling half **5** on the shaft end of the motor **2**.
7. ➤ Check the distance between the face of the coupling teeth and the connecting surface of the motor flange. The distance has to be adjusted to the value **X-E**, see Limit values for aligning the shaft coupling table ↪ Connection, Page 17.
8. ➤ Tighten the fixing screw **6** on the motor-side coupling half **5** and insert the coupling intermediate ring **4**.
9. ➤ Place the pump **1** with pump bracket **3** on the motor **2**.
10. ➤ Turn the pump slightly until the teeth of the pump-side coupling half **10** meshes correctly into the spaces of the coupling intermediate ring **4**.
11. ➤ Tighten the socket screws **7** between the motor **2** and pump bracket **3** crosswise with torque.

## 12.6 Replacing the ball bearing and radial shaft seal

### 12.6 Replacing the ball bearing and radial shaft seal

#### 12.6.1 Removing the ball bearing and radial shaft seal

Personnel qualification:	<input type="checkbox"/> Fitter
Personal protective equipment:	<input type="checkbox"/> Work clothing <input type="checkbox"/> Protective gloves <input type="checkbox"/> Safety boots
Aids:	<input type="checkbox"/> Tool set, radial shaft seal ↗ Spare parts, Page 42 <input type="checkbox"/> Plastic hammer <input type="checkbox"/> Extractor

#### Requirement:

- ✓ Pump unit disconnected from the electrical power supply, deenergized and secured against being switched back on
- ✓ Coupling removed

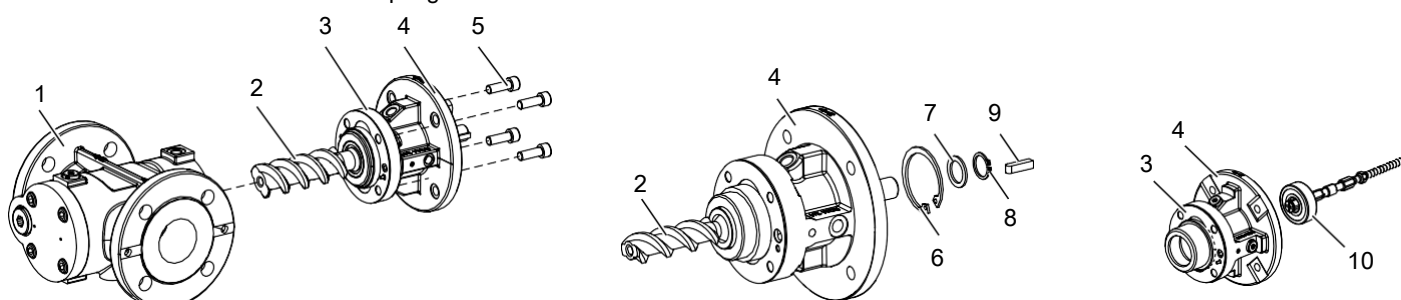

1. ➤ Remove the socket screws **5** and loosen the pump flange **4** using light “rebound” blows.
2. ➤ Pull the withdrawable unit (main screw **2** with pump flange **4**) out of the pump housing **1**.
3. ➤ Remove the feather key **9**.
4. ➤ **Size 5 – 1700** and **KFT/KVT/KFN**: Remove the circlip **8** and the supporting ring **7**.  
**Size 2200 – 2900**: Remove the threaded ring (left-hand thread) (no illustration).
5. ➤ Remove the circlip **6**.
6. ➤ Press the main spindle **2** out of the pump flange **4**.  
**Size 5 – 20** and **851 – 2900**: The supporting ring (no illustration) is removed during dismantling.  
**Size 5 – 20**: The circlip (no illustration) is destroyed during dismantling.
7. ➤ Pull the ball bearing **10** out of the pump flange **4** using an extractor.
8. ➤ Remove the residues of the flat gasket **3** carefully from the pump flange **4** and pump housing **1**.

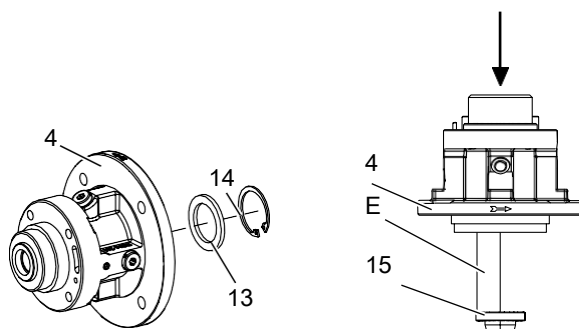

9. ➤ Remove the circlip **14**.
10. ➤ **Size 5 – 275**: Remove the supporting ring **13**.
11. ➤ Press the radial shaft seal ring **15** out of the pump flange **4** using the mounting arbour **E**. The radial shaft seal ring is destroyed during dismantling.



### 12.6.2 Mounting the ball bearing and radial shaft seal

Personnel qualification:	<input type="checkbox"/> Fitter
Personal protective equipment:	<input type="checkbox"/> Work clothing <input type="checkbox"/> Protective gloves <input type="checkbox"/> Safety boots
Aids:	<input type="checkbox"/> Tool set, radial shaft seal ↗ Spare parts, Page 42 <input type="checkbox"/> Thread sealant (for example Loctite 572) <input type="checkbox"/> Molybdenum disulphide paste (for example Fenkart T4)

**Note** The thread sealant serves during installation of the radial shaft seal as a lubricant, and after it has cured as an anti-rotation measure.

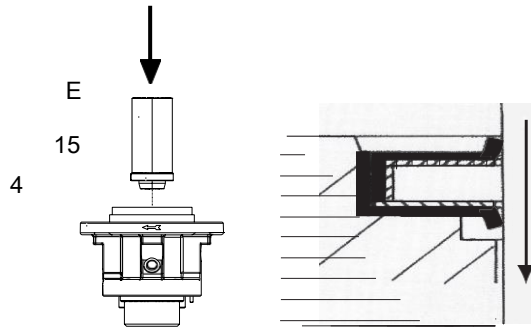

1. ➤ Clean the contact surface of the radial shaft seal ring **15** in the pump flange **4** carefully.
2. ➤ Apply a thread sealant (for example Loctite 572) as a lubricant. Ensure that the thread sealant does not come into contact with the sealing lip.
3. ➤ Carefully press the radial shaft seal ring **15** into the pump flange **4** using the mounting arbour **E**. Take the mounting direction into account. In the case of excessive resistance apply additional thread sealant.
4. ➤ Ensure that the mounting arbour **E** contacts the support of the seal ring flat and that there are no sharp edges in the area of the sealing lip.
5. ➤ Fill the radial shaft seal ring **15** with molybdenum disulphide paste ( $\text{MoS}_2$ ).

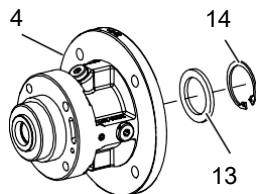

6. ➤ **Size 5 – 275:** Mount the supporting ring **13**.
7. ➤ Mount the circlip **14**.

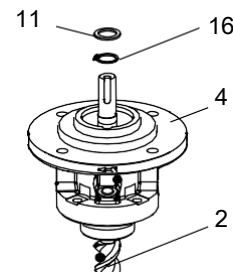
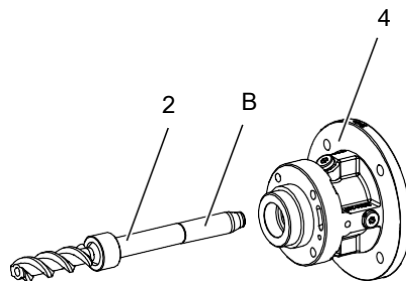

8. ➤ Push the main spindle **2** into the pump flange **4**. To do so use the main spindle mounting sleeve **B**.
9. ➤ Remove the main spindle mounting sleeve **B**.
10. ➤ **Size 5 – 20:** Mount the circlip **16** and the supporting ring **11**.

## 12.7 Replacing the screw set

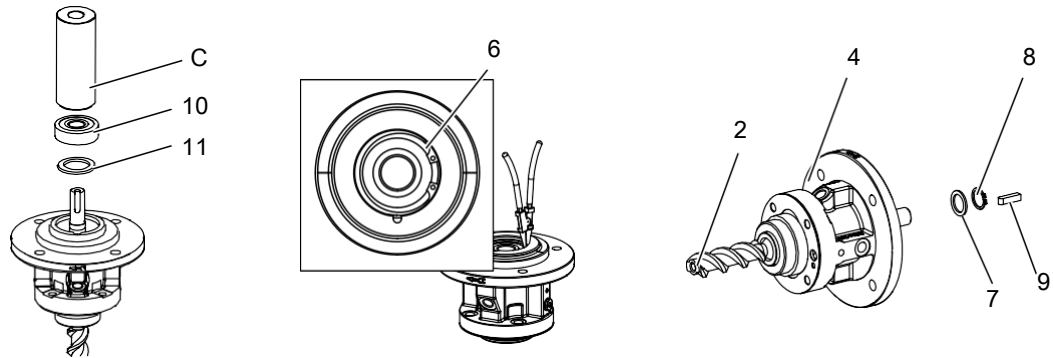

11. ➤ **Size 851 – 2900:** Insert the supporting ring **11** into the pump flange **4**.
12. ➤ Press the ball bearing **10** with mounting sleeve ball bearing **C** into the pump flange **4** up to the end position.
13. ➤ Fix the ball bearing with the circlip **6**.
14. ➤ Turn the pump flange **4** and press the main spindle **2** into the ball bearing **10**.
15. ➤ **Size 5 – 1700:** Mount the supporting ring **7** and circlip **8**.
16. ➤ **Size 2200 – 2900:** Mount the threaded ring (left-hand thread) (no illustration).
17. ➤ Mount the feather key **9**.

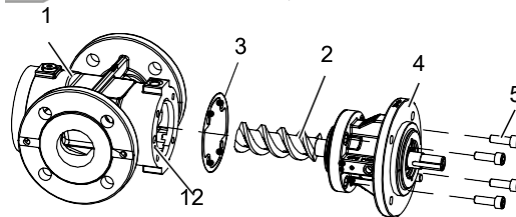

18. ➤ Bond the new flat gasket **3** onto the pump flange **4**.
19. ➤ Slide the withdrawable unit (main screw **2**, with premounted pump flange **4**) into the pump housing **1** until the main screw engages into the idle screws. Turn the main spindle while doing so. Note the position of the straight pin **12**.
20. ➤ Tighten the socket screws **5** with torque.
21. ➤ Let the thread sealant cure for 72 hours before commissioning the pump.

## 12.7 Replacing the screw set

### 12.7.1 Removing the screw set

Personnel qualification:	<input type="checkbox"/> Fitter
Personal protective equipment:	<input type="checkbox"/> Work clothing <input type="checkbox"/> Protective gloves <input type="checkbox"/> Safety boots
Aids:	<input type="checkbox"/> Plastic hammer <input type="checkbox"/> Extractor

#### Requirement:

- ✓ Pump unit disconnected from the electrical power supply, deenergized and secured against being switched back on
- ✓ Coupling removed
- ✓ Ball bearing and radial shaft seal removed

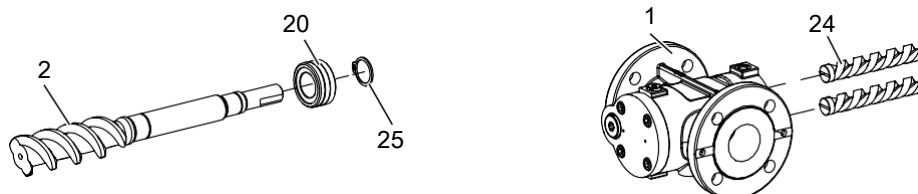

1. ➤ Remove the circlip **25** and pull the balancing cylinder **20** from the main screw **2**.
2. ➤ Pull the idle screws **24** from the pump housing **1**.

### 12.7.2 Installing the screw set

Personnel qualification:	<input type="checkbox"/> Fitter
Personal protective equipment:	<input type="checkbox"/> Work clothing <input type="checkbox"/> Protective gloves <input type="checkbox"/> Safety boots
Aids:	<input type="checkbox"/> Tool set, radial shaft seal ↪ Spare parts, Page 42 <input type="checkbox"/> Thread sealant (for example Loctite 572) <input type="checkbox"/> Molybdenum disulphide paste (for example Fenkart T4)

1. ➤ Clean the fitting surfaces carefully.

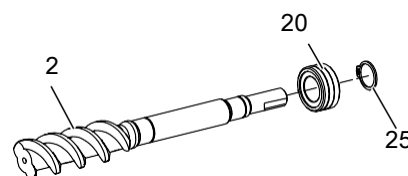
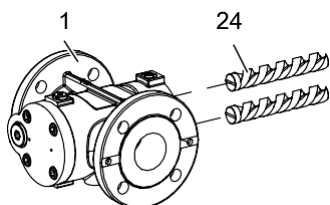

2. ➤ Insert the idle screws **24** in the pump housing **1**.
3. ➤ Press the balancing cylinder **20** onto the main spindle and fasten with the circlip **25**. Clean the main spindle **2** carefully in the area of the shaft seal and grease it.

#### Other necessary tasks ↪ Servicing, Page 28

1. ➤ Mounting the ball bearing and radial shaft seal
2. ➤ Installing the coupling

## 13 Disposal

### 13.1 Dismantling and disposing of the pump

Personnel qualification:	<input type="checkbox"/> Fitter
Personal protective equipment:	<input type="checkbox"/> Work clothing <input type="checkbox"/> Face protection <input type="checkbox"/> Protective gloves <input type="checkbox"/> Safety boots
Aids:	<input type="checkbox"/> Solvents or industrial cleaners suitable for the pumped liquid <input type="checkbox"/> Collection tank



### WARNING

#### Danger of poisoning and environmental damage through residues.

- ▶ Wear personal protective equipment during all the work. Ensure face protection.
- ▶ Before disposal collect any pumped or test liquid still present safely and dispose of it in an environmentally compatible manner in accordance with the applicable local regulations.
- ▶ Before disposing neutralize the residues.

#### Requirement:

- ✓ Disconnect the pump unit from the power supply and secure it against being switched back on
  - ✓ Pump unit cooled down to the ambient temperature and disconnected from the pipe system
  - ✓ Pump emptied completely
  - ✓ Pump placed at a location suitable for dismantling
1. ➤ Dismantle the pump and disassemble it into its individual parts.
  2. ➤ Clean residues of the pumped liquid from the individual parts.
  3. ➤ Separate sealing elements made of elastomers and ceramics (SiC) from the pump and dispose of them in separately.
  4. ➤ Recycle iron parts.

## 13.2 Possible faults

### 14 Troubleshooting

#### 14.1 Possible faults

Faults can have different causes. The following tables list the symptoms of a fault, the possible causes and measures for troubleshooting.

Identifica- Fault tion	
1	No pump suction
2	Delivery rate too low
3	Pump too loud
4	Motor overload
5	Uneven delivery rate
6	Pump has seized
7	Shaft seal leaks

#### 14.2 Troubleshooting

Fault identifica- tion		Cause	Remedy				
1	-	-	-	Pump suction line closed	Check the shut-off devices. If required, open.		
1	2	3	-	5	-	Parts soiled (filter, suction line, suction valve, strainer)	Clean parts.
1	2	3	-	5	-	Suction head too high	Reduce the level difference. -or- Reduce the line length. -or- Increase the line cross-section. -or- Heat up the pumped liquid. -or- Install a filter / strainer with a larger mesh width. Ensure that the permissible mesh width is not exceeded.
1	-	3	-	-	-	Level in the intake container too low	Fill the intake container.
1	-	-	-	-	-	Too little pumped liquid in the pump	Fill the pump with pumped liquid.
1	-	-	-	-	-	Incorrect pump direction of rotation	Swop the two electrical connection phases ↻ Connection, Page 17.
-	-	-	4	-	-	Differential pressure too high	Reduce the differential pressure.
1	-	3	4	5	-	Viscosity of the pumped liquid too high	Increase the temperature of the pumped liquid. -or- Decrease the speed.
-	2	-	-	-	-	Viscosity of the pumped liquid too low	Reduce the temperature of the pumped liquid. -or- Increase the speed.

Fault identification							Cause	Remedy
-	2	3	-	5	-	-	Airlock/gas in the pumped liquid	<ol style="list-style-type: none"> <li>1. Test the pipe system for air admission, replace leaking parts.</li> <li>2. Reduce the suction head.</li> </ol> -or- Increase the inlet pressure.
-	2	-	4	-	-	-	Speed/frequency/voltage of the motor false	<ol style="list-style-type: none"> <li>1. Ensure that the motor frequency and voltage match the operating voltage.</li> <li>2. Ensure that the speed of the motor matches the rating plate of the pump. If necessary adjust the speed.</li> </ol>
-	2	3	-	5	-	-	Overflow valve opens during normal operation	Set the opening pressure to 110% of the differential pressure ↪ During operation, Page 24.
-	2	-	-	5	-	-	Overflow valve leaks	Contact the manufacturer.
-	2	-	-	-	-	-	Advanced wear of the housing/screw set	Contact the manufacturer.
-	-	-	-	-	-	7	Advanced wear of sealing surfaces	Replace the seal and check the pumped liquid for abrasive substances. If required, replace the filter/strainer. -or- Contact the manufacturer.
-	-	3	-	-	-	-	Coupling aligned incorrectly	Assemble the coupling and motor correctly ↪ Connection, Page 17
-	-	3	-	-	-	-	Pump subject to mechanical stress	Connect the pump correctly to the pipe system ↪ Connection, Page 17.
-	-	3	-	-	-	-	Vibrations/pulsations in the system	Bear the pump unit elastically. -or- Make the connections with hoses.
-	-	3	-	-	-	-	Flow speed in the pressure line or suction line too high	Set the flow speed in the pressure line so that it does not exceed 3 m/s. -or- Set the flow speed in the suction line so that it does not exceed 1 m/s. -or- Contact the manufacturer.
-	-	3	4	-	-	7	Ball bearing damaged	Replace the ball bearing ↪ Servicing, Page 28.
-	2	3	4	-	-	7	Superficial damage to pump parts coming into contact with the liquid	Contact the manufacturer.
-	-	-	-	-	-	7	Shaft seal damaged through dry running	Replace the shaft seal ↪ Servicing, Page 28.
-	-	-	-	-	-	7	Inlet pressure too high	<ol style="list-style-type: none"> <li>1. Reduce the inlet pressure at the system side.</li> <li>2. Replace the shaft seal ↪ Servicing, Page 28.</li> </ol>
-	-	-	-	-	-	7	Inlet pressure too low	Install a non-return valve at the pressure side.

Fault identification							Cause Remedy	
-	-	-	-	-	-	7	Shaft seal is overloaded through thermal/chemical influences	<ol style="list-style-type: none"> <li>1. Check the maximum operating temperature.</li> <li>2. Check the suitability and resistance of the elastomers with regard to the pumped liquid.</li> </ol> -or- Contact the manufacturer.
-	-	-	-	-	-	7	Overload of the shaft seal by pressure build-up during the heating process	Open the pressure-side/suction-side shut-off device in order to avoid a pressure build-up through heat expansion of the pumped liquid.
1	2	3	4	5	-	-	Cold start when delivering high-viscosity liquids	Install the heating system.
-	-	-	4	-	-	7	Foreign bodies in the pump	Contact the manufacturer.
-	-	3	-	-	-	6	Differential pressure is too high and has overloaded the idle screws	Contact the manufacturer.
-	-	3	-	-	-	6	Viscosity is too low and has overloaded the idle screws	Contact the manufacturer.
1	2	3	4	-	-	7	Pump damaged through dry running	Contact the manufacturer.
1	-	-	-	-	-	-	Pump does not vent	Vent the pressure line at the highest point.

Tab. 13: Fault table

## 15 Accessories

### 15.1 Heating

#### 15.1.1 Possible types of heating

The pump can optionally be equipped with a heating system. The manufacturer recommends a heating system at high-viscosity pumped liquids that do not flow sufficiently if not heated. This can result in excessive wattage or in problems arising through cavitation or sealing.

Possible types of heating:

- Electrical heating system
- Fluid heating system
- Special heating system

#### 15.1.2 Electrical heating system

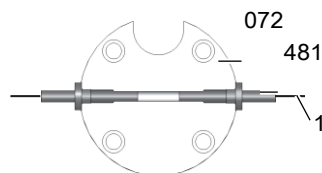

- 072** Heating cover
- 481** Heating element
- 1** Connecting cable

Fig. 12: Electrical heating system

The electrical heating system consists of one or two heating elements **481** that are integrated in a heating cover **072** attached additionally to the end cover. The output of the elements corresponds to the radiation losses and convection losses of the pump in the required temperature range so that overheating is not possible.

Size 5 – 118	Size 160 – 2900
1 heating element	2 heating elements
1 heating cover	1 heating cover
4 socket screws	4 socket screws

Tab. 14: Scope of delivery of electrical heating system

### Operating data

Parameter	Unit	Value
Voltage	[V]	230
Frequency	[Hz]	50/60
Wire cross-section	[mm <sup>2</sup> ]	2 x 1

Tab. 15: Operating data electrical heating system

### Heating-up period

Required heating-up period for temperature differences of 30 °C or 50 °C:

Size	Wattage [W]	Heating-up period [min] at a temperature difference of	
		30 °C	50 °C
5 – 42	1 x 100	20	35
55 – 118	1 x 220	20	35
160 – 275	2 x 180	25	45
370 – 450	2 x 180	30	60
550 – 660	2 x 250	45	75
851 – 1301	2 x 250	60	90
1500 – 1700	2 x 250	75	120
2200 – 2900	2 x 250	90	150

Tab. 16: Heating-up period for electric heating system

### Installing the electrical heating system

Personnel qualification:	<input type="checkbox"/> Electrician
Personal protective equipment:	<input type="checkbox"/> Work clothing <input type="checkbox"/> Protective gloves <input type="checkbox"/> Safety boots

## ATTENTION

**Damage to the electrical heating system through leakage currents or flashovers at the emission point of the connecting cable.**

- ▶ Protect the area of the connecting head against liquid and pasty liquids (lubricants, oil, plastics, etc.) as well as their vapours.

Requirement:

- ✓ Area of the connecting head protected against liquid and pasty liquids (lubricants, oil, plastics, etc.) as well as their vapours.
- ✓ Supply lines protected against mechanical vibrations in the area of the emission from the heating element. Any vapours arising have to escape freely.
- ✓ Heating element absolutely dry.

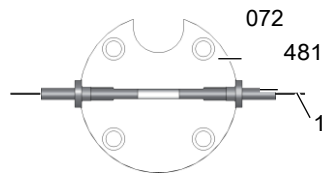

- 072** Heating cover
- 481** Heating element
- 1** Connecting cable

Fig. 13: Installation of electrical heating system

1. ➤ Remove the socket screws and rating plate at the end cover of the pump.
2. ➤ Mount the heating cover **072** to the end cover using the supplied socket screws.
3. ➤ Screw the heating element **481** into the heating cover **072**.
4. ➤ Mount the rating plate on the heating cover **072**.

### Connecting the electrical heating system



#### DANGER

#### Risk of death resulting from electric shock.

- ▶ Ensure that the electrical power supply is de-energized and is secured against being switched back on.
- ▶ Observe the operating instructions of the electrical components.

➔ Connect the connecting cable of the heating element.

### Commissioning the electrical heating system



#### DANGER

#### Risk of injury through discharging pumped liquid.

The pump housing may burst through heat expansion of the pumped liquid.

- ▶ Open all the valves during the heating process.

1. ➤ Switch on the electric heating system.
2. ➤ Take the required heating-up periods into account ↪ Accessories, Page 38.

### 15.1.3 Fluid heating system

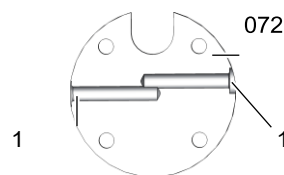

- 072** Heating cover
- 1** Pipe connection

Fig. 14: Fluid heating system

The fluid heating system consists of a heating cover **072** attached additionally to the end cover through which a heating fluid (for example vapour, thermal oil) flows.

Scope of delivery:

#### Size K 5–2900

1 heating cover

4 socket screws

Tab. 17: Scope of delivery of the fluid heating system



## Heating liquid operating data

Parameter	Unit	Value
Max. allowable working pressure	[bar]	16
Max. temperature	[°C]	200

Tab. 18: Heating liquid operating data

## Heating-up period

Required heating-up period for the temperature difference of 50 °C at a liquid temperature of 200 °C:

Size	Heating-up period [min] at a temperature difference of 50 °C
5 – 118	20
160 – 275	45
370 – 450	60
550 – 660	90
851 – 1301	120
1500 – 1700	150
2200 – 2900	180

Tab. 19: Heating-up period for fluid heating system

## Installing the fluid heating system

Personnel qualification:	<input type="checkbox"/> Fitter
Personal protective equipment:	<input type="checkbox"/> Work clothing <input type="checkbox"/> Protective gloves <input type="checkbox"/> Safety boots

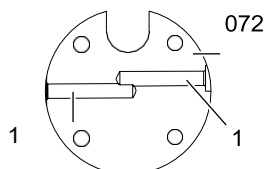

- 072** Heating cover
- 1** Pipe connection

1. ➤ Remove the socket screws and rating plate at the end cover of the pump.
2. ➤ Mount the heating cover **072** to the end cover using the supplied socket screws.
3. ➤ Mount the piping at the pipe connections **1**.
4. ➤ Mount the rating plate on the heating cover.

## Commissioning the fluid heating system



### DANGER

#### Risk of injury through discharging pumped liquid.

The pump housing may burst through heat expansion of the pumped liquid.

- ▶ Open all the valves during the heating process.

1. ➤ Take the required heating-up periods into account ↪ Accessories, Page 38.
2. ➤ When setting the pressure and temperature of the heating fluid take the permissible operating limits of the pump into account ↪ Technical data, Page 8.

### 15.1.4 Heating system special design

Please contact the manufacturer for special designs.

## 16 Spare parts

### 16.1 Overview

Model/Size	Type	Variant	Internal
KF/KH/KV 5 – 660	Maintenance kit	Radial shaft seal Standard/High-temperature	OPW 09
KF/KH/KV 851 – 1303	Maintenance kit	Radial shaft seal Standard/High-temperature	OPW 10
KF/KH/KV 1500 – 1700	Maintenance kit	Radial shaft seal Standard/High-temperature	OPW 11
KF/KH/KV 2200 – 2900	Maintenance kit	Radial shaft seal Standard/High-temperature	OPW 12
KFT/KVT/KFN	Maintenance kit	Radial shaft seal Standard/High-temperature	OPW 15
KF/KV/KV 5 – 660 and KFT/KVT/KFN/ KFA	Repair kit	Overflow valve	OPR 01
KF/KH/KV 851 – 1301	Repair kit	Overflow valve	OPR 02
KF/KH/KV 1500 – 1700	Repair kit	Overflow valve	OPR 03
KF/KH/KV 2200 – 2900	Repair kit	Overflow valve	OPR 04
K	Repair kit	Screw set	OPR 05
K	Tool set	Radial shaft seal Standard/High-temperature, ball bearing	OPR 02
KF	Spare parts	Completion	UKF
KH	Spare parts	Completion	UKF
KV	Spare parts	Completion	UKF

Tab. 20: Overview of spare parts

## 16.2 Maintenance kits

### 16.2.1 Maintenance kit radial shaft seal standard or high-temperature KF/KH/KV 5 – 660

**Note** The maintenance kit contains only the numbered parts and is only supplied complete.

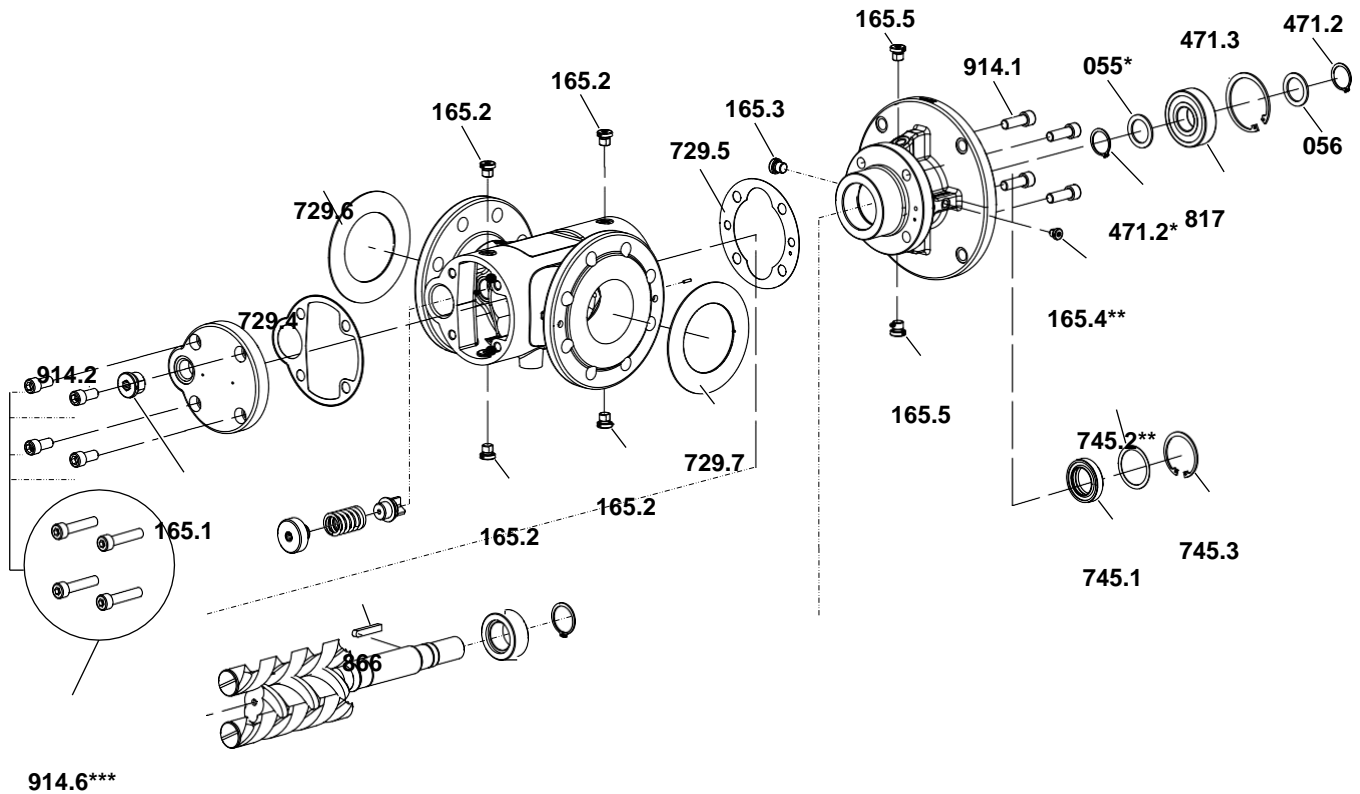

Qty.	Item No.	Part	Qty.	Item No.	Part
1	055*	Supporting ring	1	729.6	Flat gasket, suction flange
1	056	Supporting ring	1	729.7	Flat gasket, pressure flange
1	165.1	Screw plug	1	745.1	Radial shaft seal ring
4	165.2	Screw plug	1	745.2**	Supporting ring
1	165.3	Screw plug	1	745.3	Circlip
1	165.4**	Screw plug	1	817	Ball bearing
2	165.5	Screw plug	1	866	Feather key
1	471.2	Circlip	4	914.1	Socket screw
1	471.2*	Circlip	4	914.2	Socket screw
1	471.3	Circlip	4	914.6***	Socket screw
1	729.4	Flat gasket	1		MoS <sub>2</sub> paste 15 g
1	729.5	Flat gasket			
	*	Only for Size 5 – 20			
	**	Only for Size 370 – 660			
	***	Only for Type KV: replaces 914.2			

Tab. 21: Maintenance kit radial shaft seal standard or high-temperature KF/KH/KV 5 – 660

## 16.2 Maintenance kits

### 16.2.2 Maintenance kit radial shaft seal standard or high-temperature KF/KH/KV 851 – 1301

**Note** The maintenance kit contains only the numbered parts and is only supplied complete.

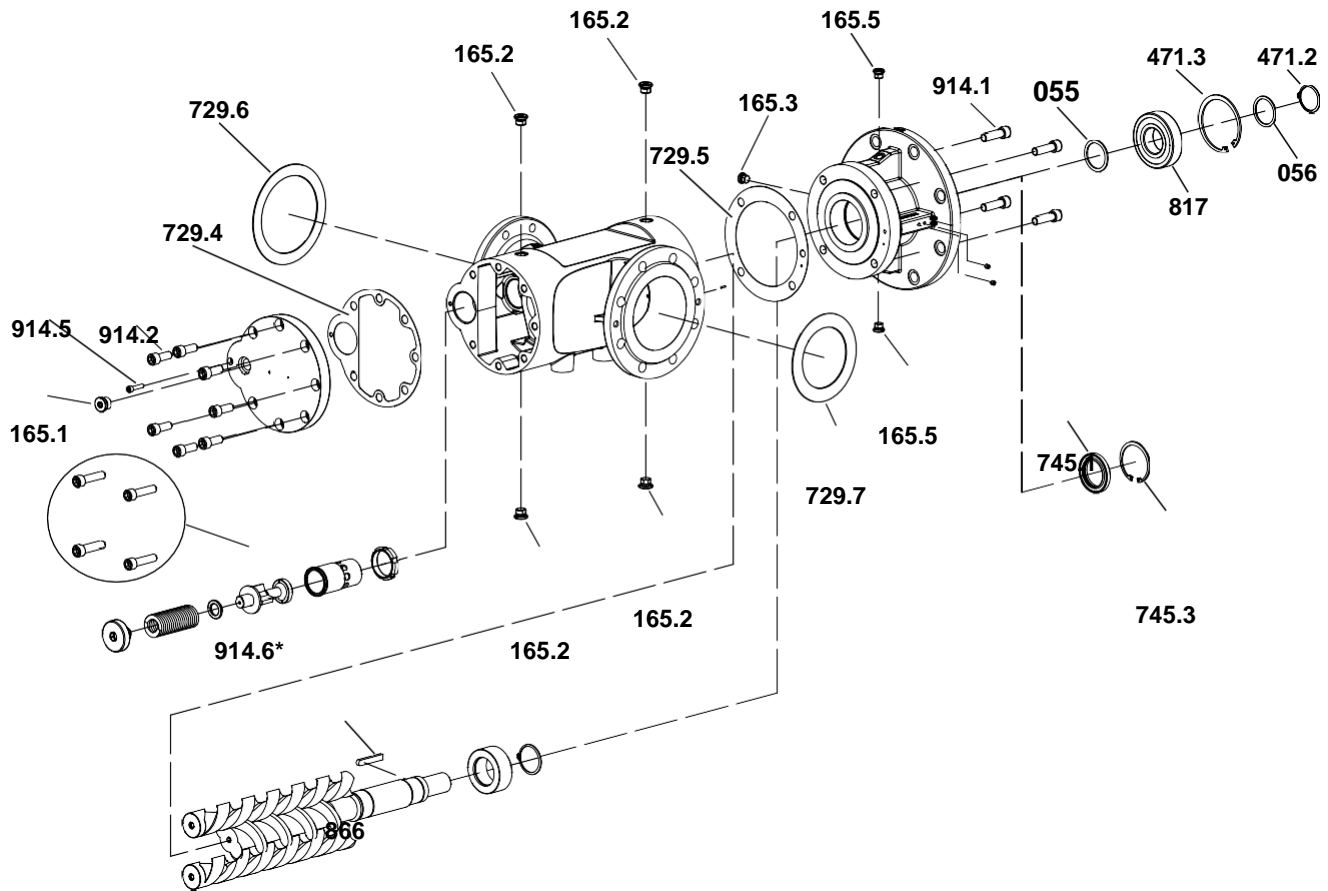

Qty.	Item No.	Part	Qty.	Item No.	Part
1	055	Supporting ring	1	729.7	Flat gasket, pressure flange
1	056	Supporting ring	1	745.1	Radial shaft seal ring
1	165.1	Screw plug	1	745.3	Circlip
4	165.2	Screw plug	1	817	Ball bearing
1	165.3	Screw plug	1	866	Feather key
2	165.5	Screw plug	4	914.1	Socket screw
1	471.2	Circlip	7	914.2	Socket screw
1	471.3	Circlip	1	914.5	Socket screw
1	729.4	Flat gasket	4	914.6*	Socket screw
1	729.5	Flat gasket	1		MoS <sub>2</sub> paste 15 g
1	729.6	Flat gasket, suction flange			
	*	Only for Type KV: replaces 4 pieces 914.2			

Tab. 22: Maintenance kit radial shaft seal standard or high-temperature KF/KH/KV 851 – 1301

### 16.2.3 Maintenance kit radial shaft seal standard or high-temperature KF/KH/KV 1500 – 1700

**Note** The maintenance kit contains only the numbered parts and is only supplied complete.

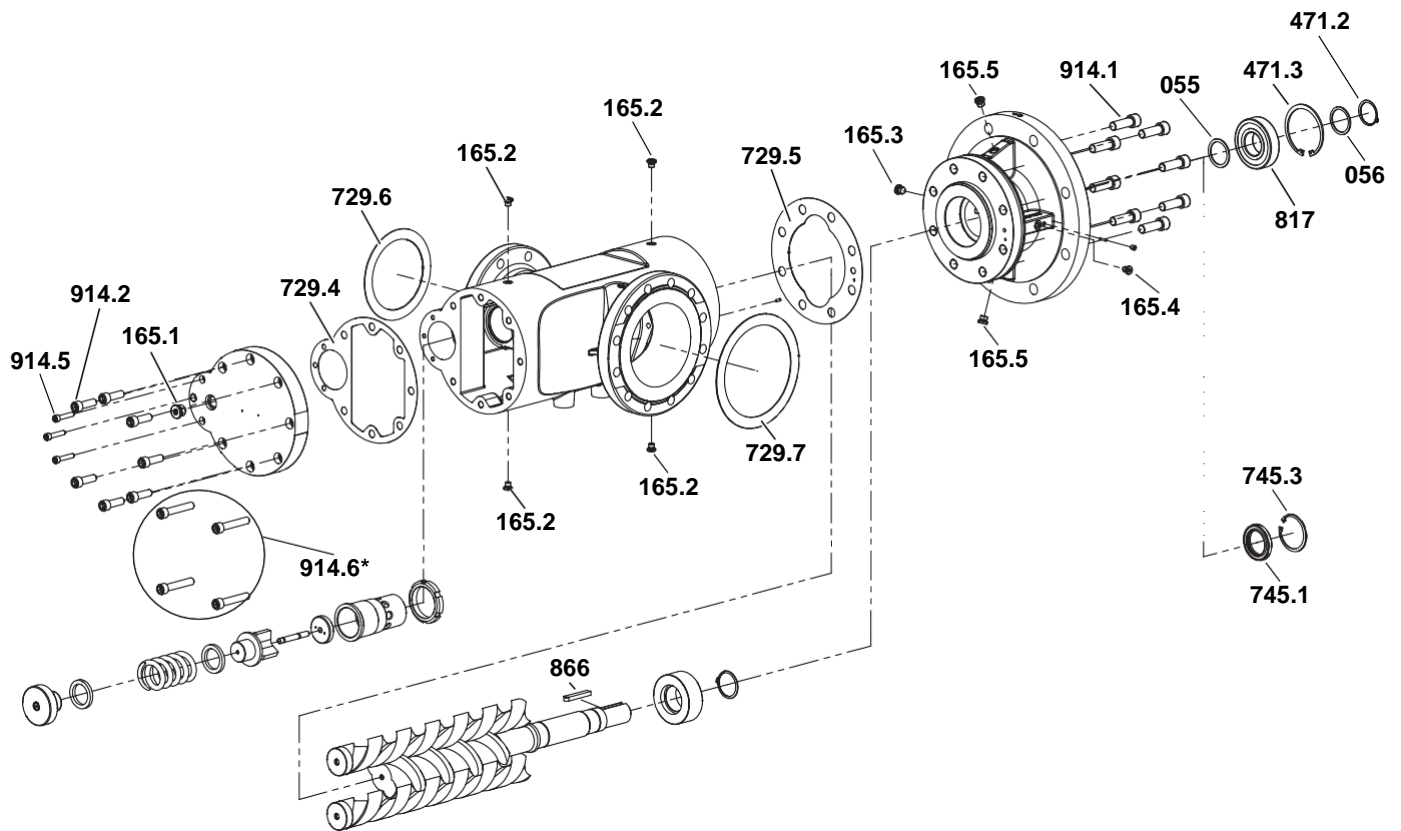

Qty.	Item No.	Part	Qty.	Item No.	Part
1	055	Supporting ring	1	729.6	Flat gasket, suction flange
1	056	Supporting ring	1	729.7	Flat gasket, pressure flange
1	165.1	Screw plug	1	745.1	Radial shaft seal ring
4	165.2	Screw plug	1	745.3	Circlip
1	165.3	Screw plug	1	817	Ball bearing
1	165.4	Screw plug	1	866	Feather key
2	165.5	Screw plug	8	914.1	Socket screw
1	471.2	Circlip	7	914.2	Socket screw
1	471.3	Circlip	3	914.5	Socket screw
1	729.4	Flat gasket	4	914.6*	Socket screw
1	729.5	Flat gasket	1		MoS <sub>2</sub> paste 15 g
	*	Only for Type KV: replaces 4 pieces 914.2			

Tab. 23: Maintenance kit radial shaft seal standard or high-temperature KF/KH/KV 1500 – 1700

## 16.2 Maintenance kits

### 16.2.4 Maintenance kit radial shaft seal standard or high-temperature KF/KH/KV 2200 – 2900

**Note** The maintenance kit contains only the numbered parts and is only supplied complete.

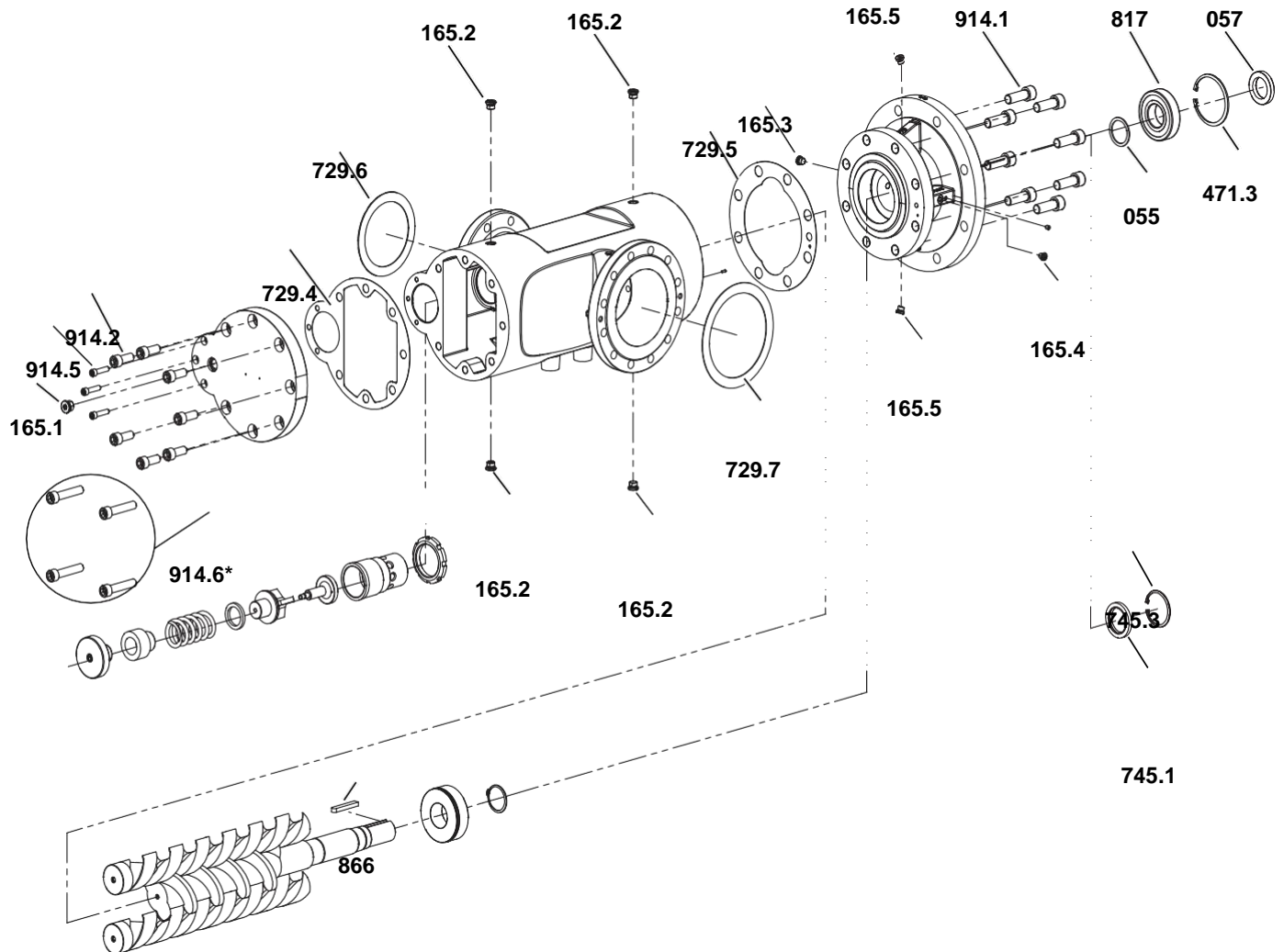

Qty.	Item No.	Part	Qty.	Item No.	Part
1	055	Supporting ring	1	729.7	Flat gasket, pressure flange
1	057	Threaded ring	1	745.1	Radial shaft seal ring
1	165.1	Screw plug	1	745.3	Circlip
4	165.2	Screw plug	1	817	Ball bearing
1	165.3	Screw plug	1	866	Feather key
1	165.4	Screw plug	8	914.1	Socket screw
2	165.5	Screw plug	7	914.2	Socket screw
1	471.3	Circlip	3	914.5	Socket screw
1	729.4	Circlip	4	914.6*	Socket screw
1	729.5	Flat gasket	1		MoS <sub>2</sub> paste 15 g
1	729.6	Flat gasket, suction flange			
	*	Only for Type KV: replaces 4 pieces 914.2			

Tab. 24: Maintenance kit radial shaft seal standard or high-temperature KF/KH/KV 2200 – 29700

## 16.2.5 Maintenance kit radial shaft seal standard or high-temperature KFT/KVT/KFN

**Note** The maintenance kit contains only the numbered parts and is only supplied complete.

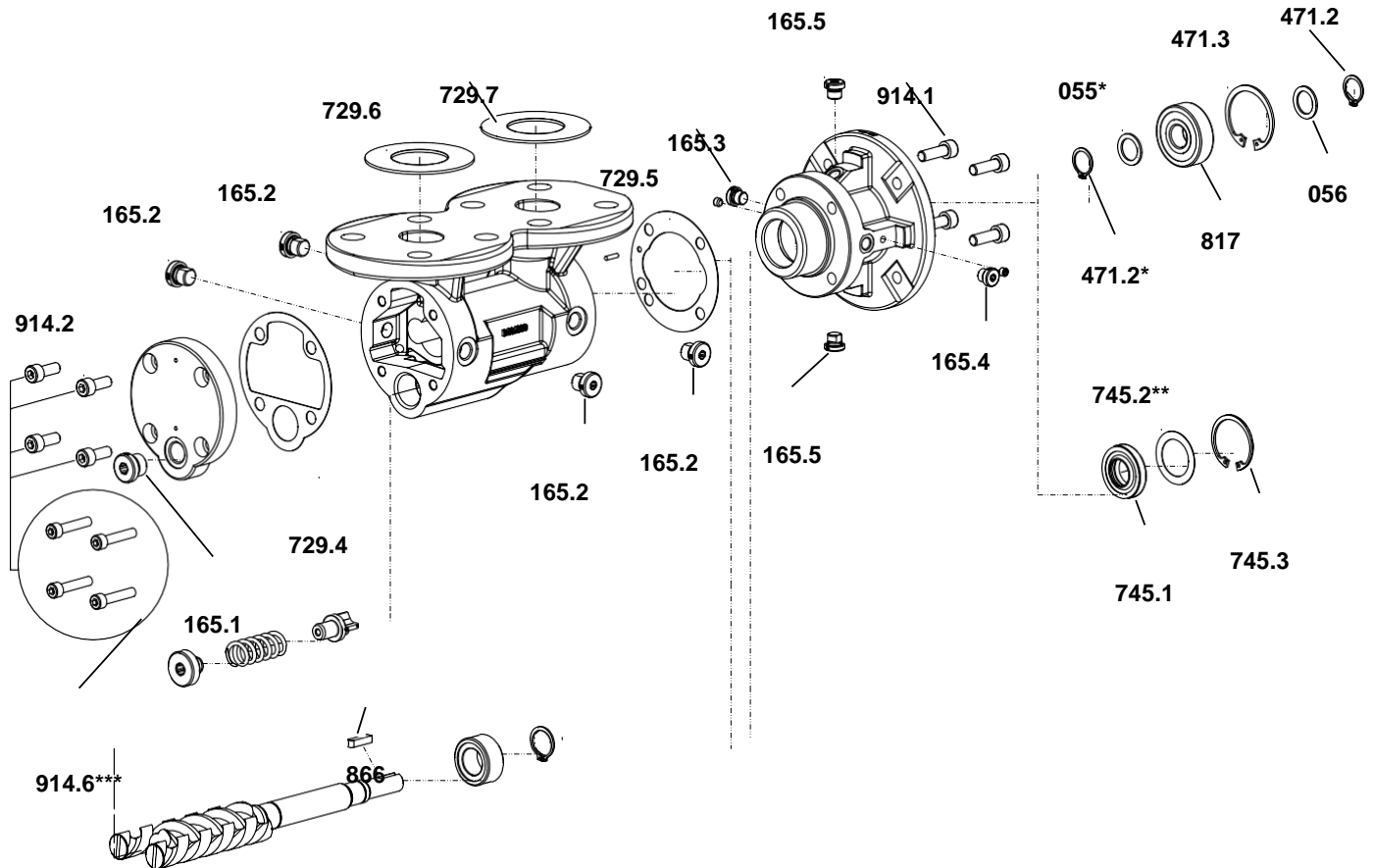

Qty.	Item No.	Part	Qty.	Item No.	Part
1	055*	Supporting ring	1	729.6	Flat gasket, suction flange
1	056	Supporting ring	1	729.7	Flat gasket, pressure flange
1	165.1	Screw plug	1	745.1	Radial shaft seal ring
4	165.2	Screw plug	1	745.2**	Supporting ring
1	165.3	Screw plug	1	745.3	Circlip
1	165.4	Screw plug	1	817	Ball bearing
2	165.5	Screw plug	1	866	Feather key
1	471.2	Circlip	4	914.1	Socket screw
1	471.2*	Circlip	4	914.2	Socket screw
1	471.3	Circlip	4	914.6***	Socket screw
1	729.4	Flat gasket	1		MoS <sub>2</sub> paste 15 g
1	729.5	Flat gasket			
	*	Only for size 5 – 20			
	**	Only for size 5 – 210			
	***	Only for Type KV: replaces 914.2			

Tab. 25: Maintenance kit radial shaft seal standard or high-temperature KFT/KVT/KFN

## 16.3 Repair kits

### 16.3 Repair kits

#### 16.3.1 Repair kit overflow valve KF/KH/KV 5 – 660 and KFT/KVT/KFN/KFA

**Note** The repair kit contains only the numbered parts and is only supplied complete.

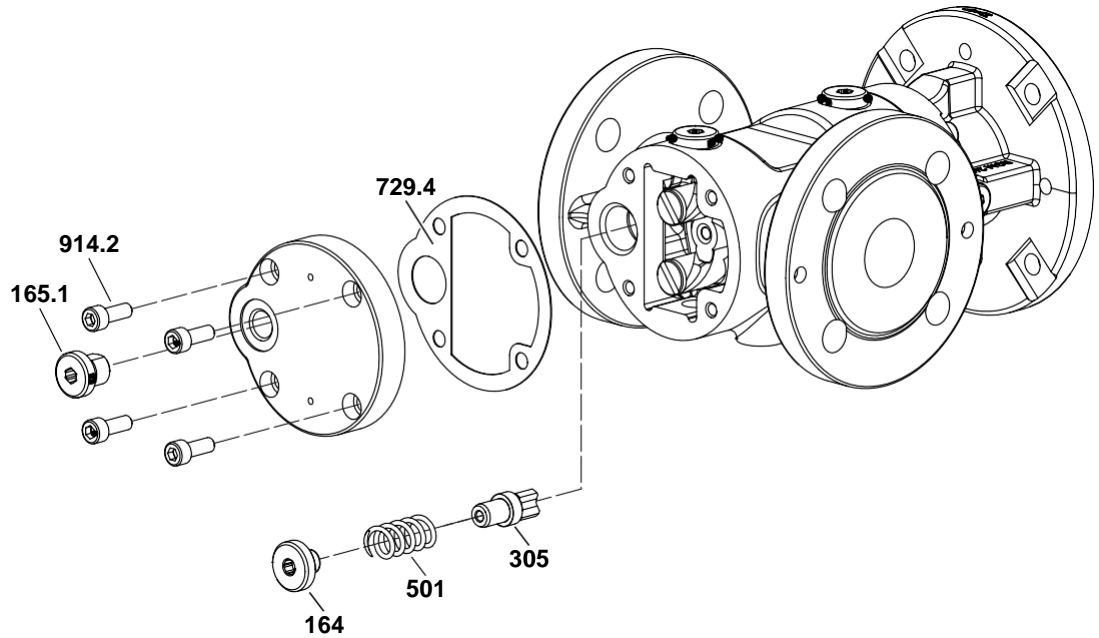

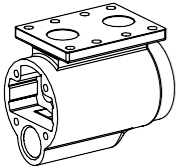
Qty.	Item No.	Part	Qty.	Item No.	Part
1	164	Adjusting screw	1	501	Pressure spring
1	165.1	Screw plug	1	729.4	Flat gasket
1	305	Valve body	4	914.2	Socket screw
		 Type KFA: Pump housing with overhead flanges in special design PN16			

Tab. 26: Repair kit overflow valve KF/KH/KV 5 – 660 and KFT/KVT/KFN/KFA



### 16.3.2 Repair kit overflow valve KF/KH/KV 851 – 1301

**Note** The repair kit contains only the numbered parts and is only supplied complete.

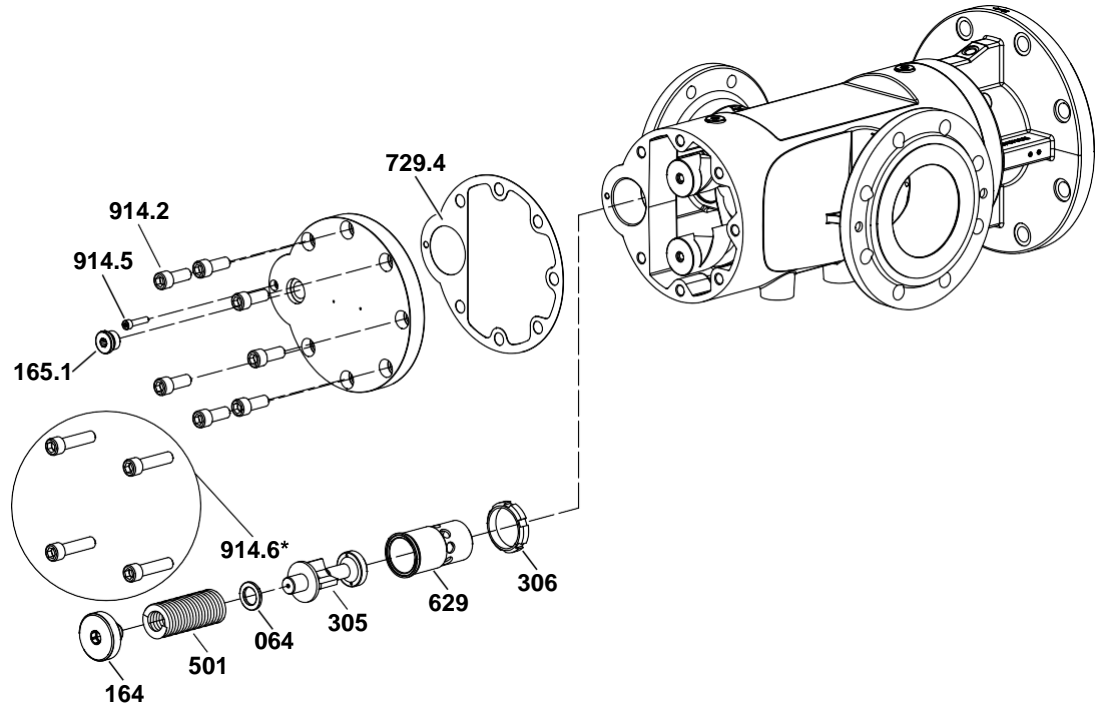

Qty.	Item No.	Part	Qty.	Item No.	Part
1	064	Supporting ring	1	629	Valve housing
1	164	Adjusting screw	1	729.4	Flat gasket
1	165.1	Screw plug	7	914.2	Socket screw
1	305	Valve body	1	914.5	Socket screw
1	306	Groove nut	4	914.6*	Socket screw
1	501	Pressure spring			
	*	Only for Type KV: replaces 4 pieces 914.2			

Tab. 27: Repair kit overflow valve KF/KH/KV 851 – 1301

## 16.3 Repair kits

### 16.3.3 Repair kit overflow valve KF/KH/KV 1500 – 1700

**Note** The repair kit contains only the numbered parts and is only supplied complete.

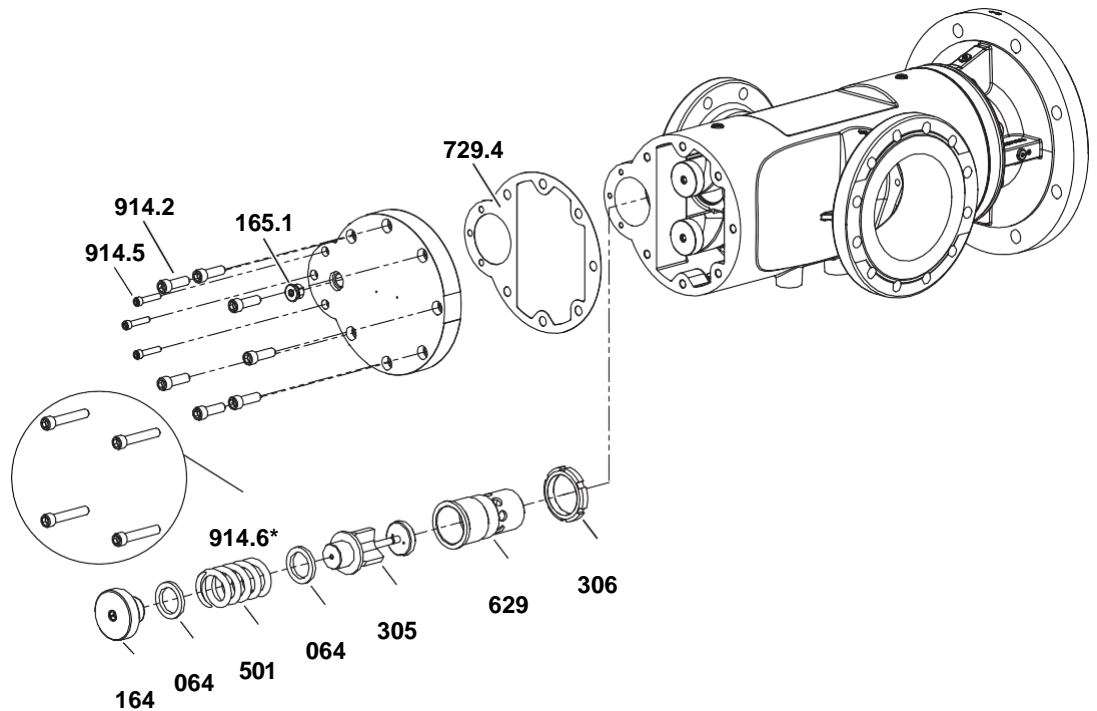

Qty.	Item No.	Part	Qty.	Item No.	Part
2	064	Supporting ring	1	629	Valve housing
1	164	Adjusting screw	1	729.4	Flat gasket
1	165.1	Screw plug	7	914.2	Socket screw
1	305	Valve body	3	914.5	Socket screw
1	306	Groove nut	4	914.6*	Socket screw
1	501	Pressure spring			
	*	Only for Type KV: replaces 4 pieces 914.2			

Tab. 28: Repair kit overflow valve KF/KH/KV 1500 – 1700

### 16.3.4 Repair kit overflow valve KF/KH/KV 2200 – 2900

**Note** The repair kit contains only the numbered parts and is only supplied complete.

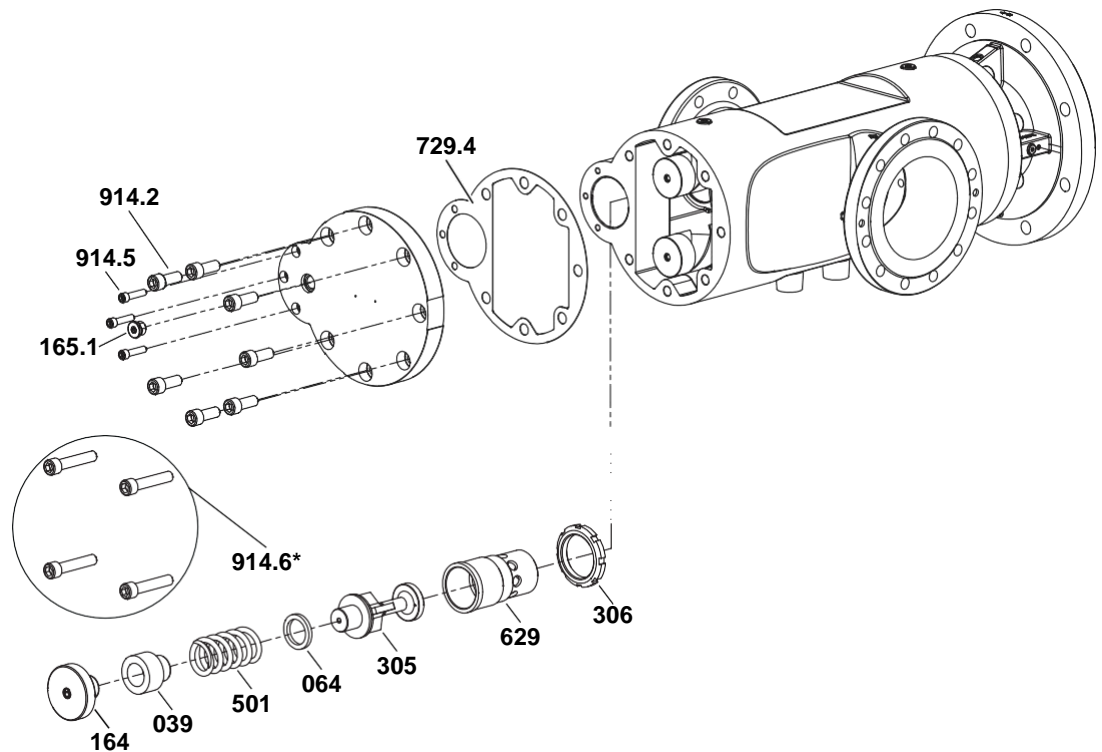

Qty.	Item No.	Part	Qty.	Item No.	Part
1	039	Sleeve	1	501	Pressure spring
1	064	Supporting ring	1	629	Valve housing
1	164	Adjusting screw	1	729.4	Flat gasket
1	165.1	Screw plug	7	914.2	Socket screw
1	305	Valve body	3	914.5	Socket screw
1	306	Groove nut	4	914.6*	Socket screw
	*	Only for Type KV: replaces 4 pieces 914.2			

Tab. 29: Repair kit overflow valve KF/KH/KV 2200 – 2900

## 16.4 Tool sets

### 16.3.5 Spindle set repair kit K

**Note** The repair kit is only supplied in combination with a maintenance kit.

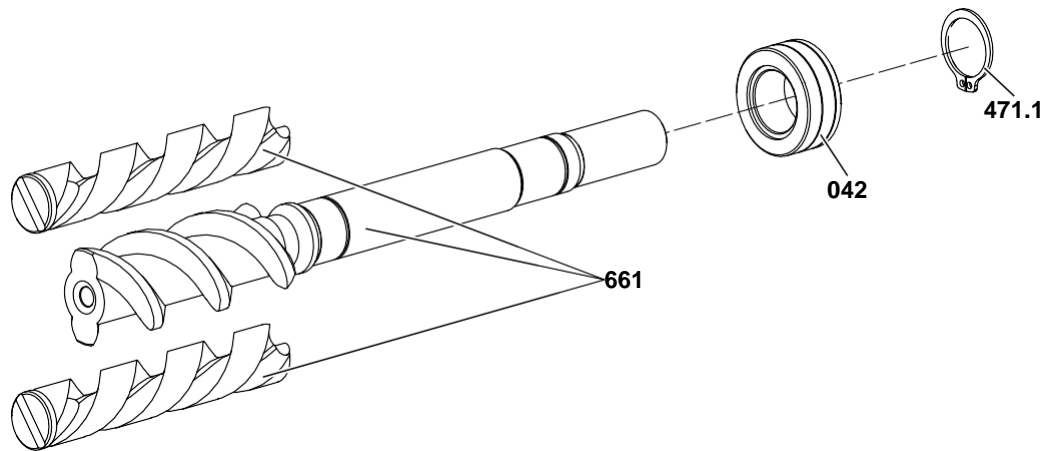

Qty.	Item No.	Part	Qty.	Item No.	Part
1	042	Balancing cylinder	1	661	Screw set
1	471.1	Circlip			

Tab. 30: Spindle set repair kit K

## 16.4 Tool sets

### 16.4.1 Radial shaft seal tool set K

		Qty.	Part
E		1	Mounting arbour radial shaft seal ring
B		1	Main screw mounting sleeve
C		1	Mounting sleeve ball bearing

## 16.5 Completions

### 16.5.1 Completion Type KF

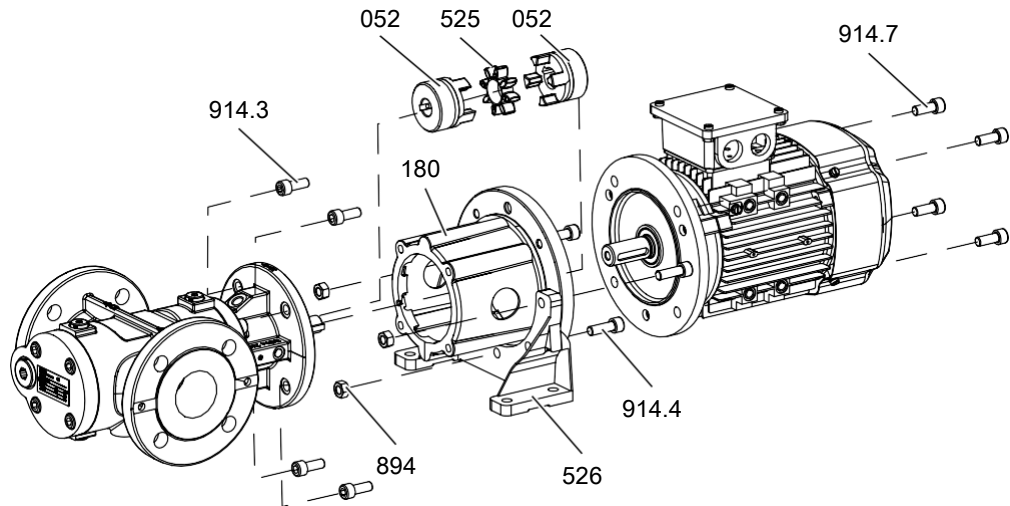

Qty.	Item No.	Part	Qty.	Item No.	Part
1	052	Coupling	3	894	Hexagon nut
1	180	Pump bracket	4	914.3	Socket screw
1	525	Coupling intermediate ring	3	914.4	Socket screw
1	526	Pump bracket foot	4	914.7	Socket screw

Tab. 31: Completion Type KF

## 16.5 Completions

### 16.5.2 Completion Type KH

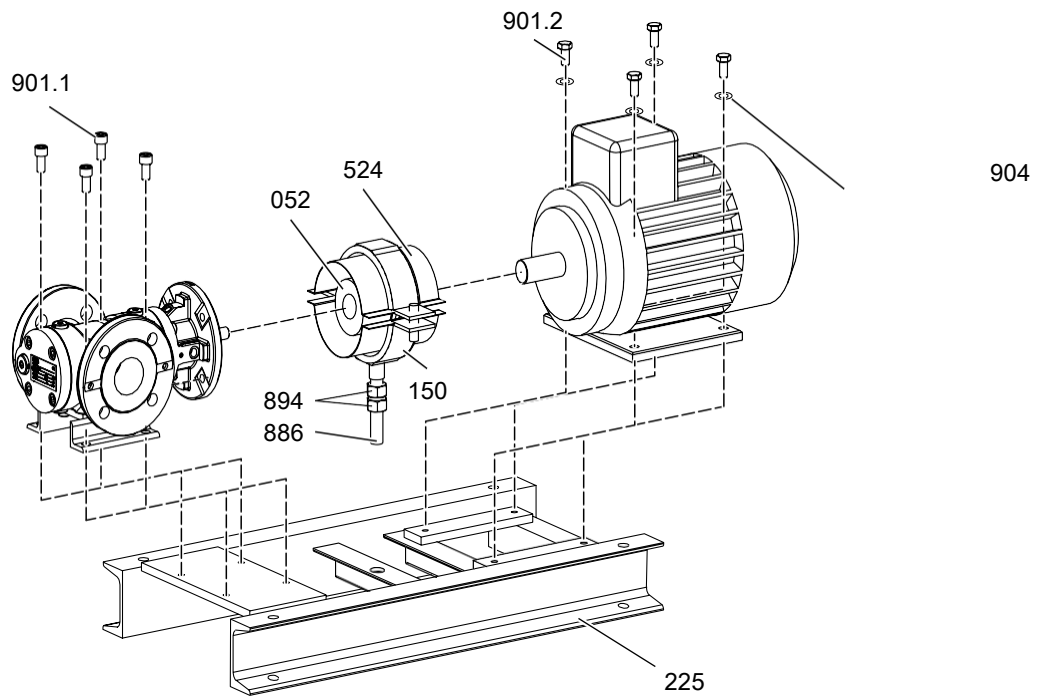

Qty.	Item No.	Part	Qty.	Item No.	Part
1	052	Coupling	2	894	Hexagon nut
1	150	Pipe clip	4	901.1	Stud screw
1	225	Base frame	4	901.2	Stud screw
1	524	Coupling protection	4	904	Wedge lock washer
1	886	Threaded rod			

Tab. 32: Completion Type KH

## 16.5.3 Completion Type KV

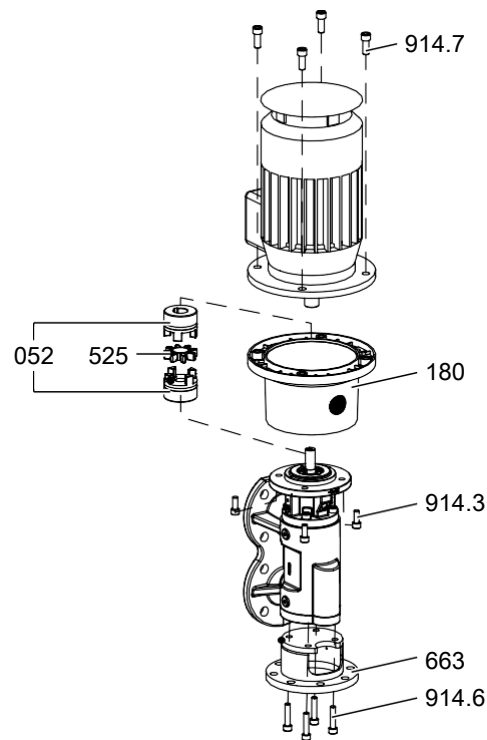

Qty.	Item No.	Part	Qty.	Item No.	Part
1	<b>052</b>	Coupling	4	<b>914.3</b>	Socket screw
1	<b>180</b>	Pump bracket	4	<b>914.6</b>	Socket screw
1	<b>525</b>	Coupling intermediate ring	4	<b>914.7</b>	Socket screw
1	<b>663</b>	Pedestal			

Tab. 33: Completion Type KV

## 17 Appendix

### 17.1 Tightening torques for screws with metric screw threads with and without wedge lock washers

#### 17 Appendix

#### 17.1 Tightening torques for screws with metric screw threads with and without wedge lock washers

**Note** In the case of galvanised screw plugs and screw plugs made of stainless steel the inner thread and outer thread have to be greased thorough before mounting in order to prevent threads from seizing.

**Note** The manufacturer recommends tightening screws with wedge lock washers according to the table three times after another with the same tightening torque

Tightening torque [Nm]							
Screws with head contact surface							Countersunk screws
Thread	Stainless steel screws A2 and A4				Stainless steel screws A2 and A4		8.8
	5.6	8.8	10.9	8.8+ Alu*	Property class 70	Property class 80	
M 3	0.6	1.5	–	1.2	1.1	1.3	1.0
M 4	1.4	3.0	4.1	2.3	2.0	2.3	2.0
M 5	2.7	6.0	8.0	4.8	3.9	4.7	5.0
M 6	4.7	10.3	14.0	7.6	6.9	8.0	9.0
M 8	11.3	25.0	34.0	18.4	17.0	22.0	14.0
M 10	23.0	47.0	68.0	36.8	33.0	43.0	36.0
M 12	39.0	84.0	117	64.0	56.0	75.0	60.0
M 14	62.0	133	186	101	89.0	–	90.0
M 16	96.0	204	285	155	136	180	100
M 18	133	284	390	224	191	–	–
M 20	187	399	558	313	267	370	135
M 24	322	687	960	540	460	605	360

Tab. 34: Tightening torques metric screw thread

\*When screwing into aluminium, the tightening torque reduces by 20 % when the screw-in depth is less than double the thread diameter.

#### 17.2 Tightening torques for screw plugs with thread measured in inches and elastomer seal

**Note** In the case of galvanised screw plugs and screw plugs made of stainless steel the inner thread and outer thread have to be greased thorough before mounting in order to prevent threads from seizing.

Tightening torque [Nm]	
Thread	Galvanized + stainless steel
G 1/8"	13.0
G 1/4"	30.0
G 3/8"	60.0
G 1/2"	80.0
G 3/4"	120
G 1"	200
G 1 1/4"	400
G 1 1/2"	450

Tab. 35: Tightening torques with thread measured in inches



### 17.3 Contents of the Declaration of Conformity

The products described in these instructions are machinery in the sense of the Directive 2006/42/EC. The original of the EC Declaration of Conformity is enclosed with the machinery at delivery.

The machinery fulfils all the relevant provisions of the following directives:

Number	Name	Remark
2006/42/EC	Machinery Directive	–
2014/68/EU	Pressure Equipment Directive	–
2014/30/EU	Directive on Electromagnetic Compatibility	Only for machinery with electrical components
2014/35/EU	Low Voltage Directive	Only for machinery with electrical components
2014/34/EU	Directive on Use in Potentially Explosive Areas (ATEX)	Only for machinery in ATEX version

Tab. 36: Directives obs